



MPOD HV&LV Power Supply System

Technical Manual

General Remarks

The only purpose of this manual is a description of the product. It must not be interpreted as a declaration of conformity for this product including the product and software.

W-IE-Ne-R revises this product and manual without notice. Differences of the description in manual and product are possible.

W-IE-Ne-R excludes completely any liability for loss of profits, loss of business, loss of use or data, interrupt of business, or for indirect, special incidental, or consequential damages of any kind, even if **W-IE-Ne-R** has been advises of the possibility of such damages arising from any defect or error in this manual or product.

Any use of the product which may influence health of human beings requires the express written permission of **W-IE-Ne-R**.

Products mentioned in this manual are mentioned for identification purposes only. Product names appearing in this manual may or may not be registered trademarks or copyrights of their respective companies.

No part of this product, including the product and the software may be reproduced, transmitted, transcribed, stored in a retrieval system, or translated into any language in any form by any means with the express written permission of **W-IE-Ne-R**.

Control Cabinet

In the context of this user manual, the control cabinet must fulfill the requirements on fire-protective enclosures according to EN 60950 / IEC 60950 / UL 60950.

All devices are intended for operation in control cabinets or in closed areas. The LAN connection and all wire connections between the different system parts must be done via shielded cable with conductive connector shells, which are fixed with screws.

Furthermore, an additional fire-protective enclosure is required which must not affect proper air circulation.

Mains Voltage and Connection

The Power supplies are equipped with a “World”- mains input (rated voltage range: 100-240 VAC, frequency: 50-60 Hz, rated current: 16 A). Before connecting to the mains please double-check correspondence.

Mains input connection at the power supply side is done with a 3-pin HIRSCHMANN connector or power terminals. There is no main fuse inside. A circuit breaker for overcurrent protection 16A, type B or C (EN / IEC 60898, VDE 0641), has to be installed externally.

Before disconnection the HIRSCHMANN connector, the power supply should be switched into standby state. (Use the ON/OFF-Switch of the front pannel of the MPOD system)

Hirschmann.	Signal	Description	Color of the Wire
Pin 1	L	Phase	black or brown
Pin 2	N	Return, Neutral	blue
Pin 3		not connected	
Earth	PE	Protective Earth	green/yellow

Connection to Earth

Safety

After connecting the Power box to the mains, the mains input module is powered permanently. Filter and storage capacitors of the power factor correction module are charged with about **400VDC**. Any DC-On-Signal as well as a power switch at control board (if any installed) operates as a low voltage DC on/off switch only and not as a mains breaker. **Therefore it becomes dangerous if the box cover is open. In this case a lot of components on high voltage potential get touchable!**

Before starting any kind of work inside the power box remove the unit from mains and wait a couple of minutes with your activities! Discharge the primary DC Filter-capacitors by use of a well isolated 22 ohm 10W resistor.

We recommend in case of any malfunction to send the power box to Wiener or to one of our representative for service



The backplane is connected to 385 V DC voltage. So never touch the backplane or its connectors!

The HV-Modules produce very high voltage which may be mortal danger if handled improperly. Please read the separate manuals of the HV modules for detailed information!

Declaration of Conformity

Low Voltage Directive 73/23/EEC and EMC Directive Art. 10.1 of 89/336/EEC

W-IE-NE-R

Plein & Baus GmbH

declare under our own responsibility that the product

MPOD Power Supply System

Items: 0MPV.xxxx, 0BP0.9003, 0316.0070, 0R00.0002

is in accordance with the following standards or standardized documents:

- | | | |
|----|--|--|
| 1. | EN 60 950-1:2001
+ Corr:2004-09 | Niederspannungsrichtlinie [low voltage directive] |
| 2. | EN 61 000-6-3:2001
EN 55 022:1998
+ Corr:2001 + A1:2000 Kl. B
EN 55 022:1998
+ Corr:2001 + A1:2000 Kl. B
EN 61 000-3-2:2001
EN 61 000-3-3:1995 +Corr:1997 +A1:2001 | Störaussendung EMA [RF emission]
Störspannung [conducted noise]

Störfeldstärke [radiated noise] |
| 3. | EN 61 000-6-2:2001
EN 61 000-4-6:1996 + A1:2001
EN 61 000-4-3:1996 + A1:1998 + A2:2001

EN 61 000-4-4:1995 + A1:2001
EN 61 000-4-5:1995 + A1:2001
EN 61 000-4-11:1994 + A1:2000

EN 61 000-4-2:1995 + A1:1998 + A2:2001 | Oberschwingungen [harmonics]
Spannungsschwankungen [flicker]
Störfestigkeit EMB [immunity]
HF-Einströmung [injected HF currents]
HF-Felder [radiated HF fields] incl. "900MHz"
Burst
Surge
Spannungs-Variationen [voltage variations]
ESD |

Conditions:

This unit is not a final product and is foreseen for use inside a closed cabinet. The supplying of loads over long distances (>3m) needs possibly additional RF rejection hardware to get in conformity of the definition.

Name and signature of authorized person

Place and Date

Manfred Plein

Techn. Director
April 2008

Contents

Declaration of Conformity.....	iii
1 General Information.....	1
1.1 MPOD Features	1
1.2 MPOD Crate - standard types.....	2
1.3 MPOD Mini crate.....	3
1.4 MPOD Micro crate.....	4
2 LV Modules.....	5
2.1 MPOD Low Voltage Module Versions.....	6
2.2 Combined Power & Sense Connector 8 channel modules (standard female type).....	7
2.3 Combined Power & Sense Connector 4 channel modules (DSUB4W17 type).....	8
2.4 Sense & Control Connector Pin Assignment (old modules with mixed DSUB37 + DSUB37-8).....	9
2.5 Power Connector Pin Assignment (old modules with mixed DSUB37 + DSUB37-8).....	9
2.6 SAFETY LOOP and optional INTERLOCK functionality of MPV modules.....	10
3 HV Modules	11
4 MPOD Controller.....	13
5 Local Control	15
5.1 Introduction.....	15
5.2 Usage of the rotary controls.....	15
5.3 MPOD Display Main menu.....	16
5.4 MPOD Display CHANNEL menu.....	17
5.5 MPOD Display Key-lock function.....	18
5.5.1 Lock the System.....	18
5.5.2 Unlock the System	19
5.5.3 Change the Key.....	19
6 Remote Control / Software.....	20
6.1 MUSEcontrol Software Microsoft Windows.....	20
6.1.1 Software Installation.....	20
6.1.2 First Start.....	20
6.1.3 Network Setup / Configuration.....	21
6.1.4 Enable / Disable MPOD controller interlock.....	21
6.1.5 MPOD Controller Firmware Updates.....	21
6.1.6 WIENER MPV8xxx and MPV4xxx Operation.....	21
6.2 Web Browser.....	22
6.3 NetSNMP.....	23
6.3.1 SNMP commands and community groups.....	23
6.3.2 SNMP command help.....	24
6.3.3 Basic SNMP communication and channel control.....	24

6.3.4	Special commands for ISEG high voltage modules.....	29
6.3.5	Special commands for WIENER low voltage modules.....	35
6.3.6	MPOD “module” parameters.....	35
6.3.7	MPOD Chassis, fan tray and power supply parameters.....	37
6.3.8	ISEG HV Load Unit module commands.....	38
6.4	Change of community names / setting of passwords.....	38
6.5	MIB Browser.....	39
6.6	A BASH Simple Script for SNMP.....	40
6.7	MPOD SNMP Parameter List (most common).....	42
6.8	LabView Control Program (NETSNMP).....	43
6.9	ISEG SNMP Control Program (NETSNMP).....	43
6.10	C++ programming (NetSNMP).....	44
7	MPOD Crate.....	46
8	Primary Power Supply.....	46
8.1	Power Box Data Sheet.....	46
9	MPOD Low Voltage module MPV 8xx data sheet.....	47
10	SNMP examples for MPOD and high voltage EHS/EDS module.....	49
11	WIENER SNMP Parameter structure.....	52
12	MPOD Firmware Update.....	61
13	MPOD Display Firmware Update.....	65
14	ISEG HV Module Firmware Update via Ethernet / SNMP.....	67

Figures

Tables

1 General Information



MPOD LX crate with mixed low and high voltage modules

1.1 MPOD Features

MPOD is a mainframe for multi-channel high voltage (HV) and low voltage (LV) power supply modules. A unique flexibility is given by outfitting the MPOD crate with either the LV or HV backplane only or with both to allow combined use of LV and HV modules. The full size MPOD crate has 10 slots for power modules which provides a high number of output channels. Its modular design makes the customer able to easily replace the fan tray, the controller, the primary power supply or the optional air filter.

- 10 module slots for up to 80 LV channels / up to 480 HV channels
- 8U high for bottom cooling air intake, optional 9U high as desktop or front / side intake with 1U dust filter
- Modules and controller outputs can be placed either at front or rear side (picture above shows front side)
- LV: 8 channels (0- 8/16/30/60V/120V, 50W / channel, floating)
- HV: 480 / 320/240 / 160 / 80 or 40 channels (0- 2.5/4/6kV/8kV/10kV), channel- or module wise floating or common ground
- Low noise and ripple
- Individually controlled output channels (voltage and current), programmable warning and trip levels
- MPOD Controller with Ethernet (TCP/IP) / CANbus / USB Combi-interface, Interlock
- Ethernet port with integrated Web server, programmable with SNMP protocol via TCP/IP, OPC Server

- CE conform EN 50 081/82 part 1 (EN 50 022 B)
- safety in accordance with EN 60 950
- Sinusoidal mains current EN 61000-3-2

1.2 MPOD Crate - standard types

The following crate types are standardized configurations with 8U high chassis. Optionally a filter frame is available with bottom or front air inlet which increases the height to 9U.

Other configurations and mixed system with part of the crate outfitted with PCI or VME backplanes are available on request.

Type	Slots	Remote control interface	Local control / Backplane display	HV power	Output Position
MPOD EC	10	Ethernet, CAN, USB	-	HV/LV	600W front
MPOD EC-R	10	Ethernet, CAN, USB	-	HV/LV	600W rear
MPOD LX	10	Ethernet, CAN, USB	Yes, LCD	HV/LV	600W front
MPOD LX-R	10	Ethernet, CAN, USB	Yes, LCD	HV/LV	600W rear
MPOD EC-LV	10	Ethernet, CAN, USB	-	LV	- front
MPOD EC-LV-R	10	Ethernet, CAN, USB	-	LV	- rear
MPOD EC-HV	10	Ethernet, CAN, USB	-	HV	600W front
MPOD EC-HV-R	10	Ethernet, CAN, USB	-	HV	600W rear
MPOD 2H	10	Ethernet, CAN, USB	-	HV	1200W front
MPOD 2H-R	10	Ethernet, CAN, USB	-	HV	1200W rear
MPOD 2H-LX	10	Ethernet, CAN, USB	Yes, LCD	HV	1200W front
MPOD 2H-LX-R	10	Ethernet, CAN, USB	Yes, LCD	HV	1200W rear

(CAN-bus for HV modules only, disabling Ethernet communication may be necessary for ISEG CAN-HV control software)

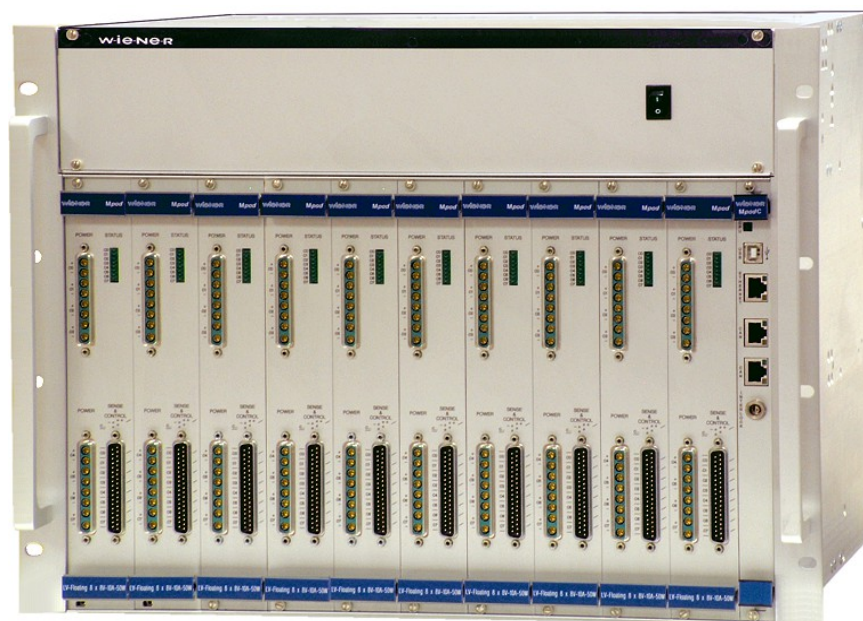

MPOD EC-LV crate with low voltage modules

Optionally, MPOD can be outfitted with a removable 1U tray for frontal air inlet and air filter underneath the bin, as shown in the following picture:

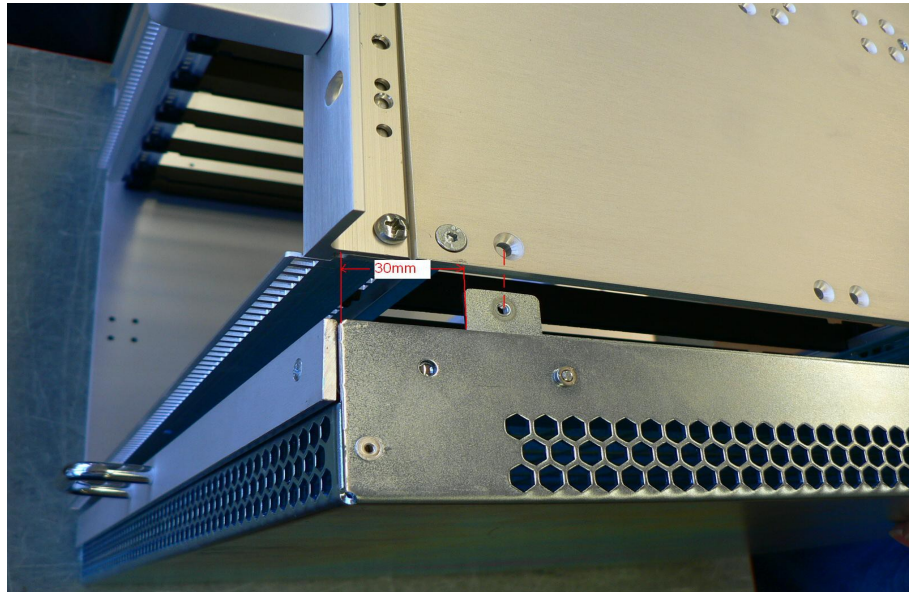

1.3 MPOD Mini crate

The WIENER MPOD mini crate represents a compact 19" rack mountable chassis for up to 4 MPOD low and high voltage modules. The MPOD mini crate includes the primary power supply with 600W power for high voltage modules as well as a cooling system with high performance DC fan. It can be outfitted with HV backplane for use as a high voltage system only or with both HV and LV backplanes.

The first half slot is reserved for the MPOD Controller which manages the primary power supplies and provides Ethernet, USB and CAN-bus interfaces for remote monitoring and control. Please note that it is possible to switch the MPOD crate off and on off remotely when the front panel switch is in ON position.



MPOD Mini crate with MPOD controller and 2 high voltage + 2 low voltage modules

1.4 MPOD Micro crate

The MPOD micro crate is the smallest and low cost option for the WIENER multi-channel high and low voltage power supply system. The MPOD micro mainframe can house 1 plug-in low or high voltage module. The integrated MPOD controller card provides 10/100 Ethernet, CAN bus and USB-2 interfaces.



MPOD micro LV crate with MPOD controller and one low voltage module MPV8008I

2 LV Modules

The MPV MPOD Low Voltage modules are available with either 4 or 8 channels for different voltage ranges with 8V, 16V, 30V, 60V and 120V maximum respectively. All MVP modules have the following features:

- 6U height, 220mm deep fully shielded mechanics
- All DC outputs with individual return lines, individually sensed, floating channel to channel and channel to chassis ground (125V, 500V tested)
- Low noise and ripple (<3mV at 20MHz bandwidth)
- Voltage and current settings / monitoring for each channel, 15 bit resolution, accuracy +/-0.1% of full scale value
- Current monitoring and limiting for each channel, 15 bit resolution, accuracy +/-0.05% of full scale value
- high stability, 0.2%/10k
- Programmable channel parameters:
 - voltage, under voltage / over voltage trip point
 - current limit
 - power, regulation type, internal / external sense
 - ramping speed up and down (1V/s ... 500V/s)
 - group features / error handling
- programming and monitoring via Ethernet (TCP/IP) and USB
- Connectors: 2 x 8 pin high current sub-D, 37 pin sub-D for sense / control or 2 x 37 pin sub-D for DC and sense (4 channels each)

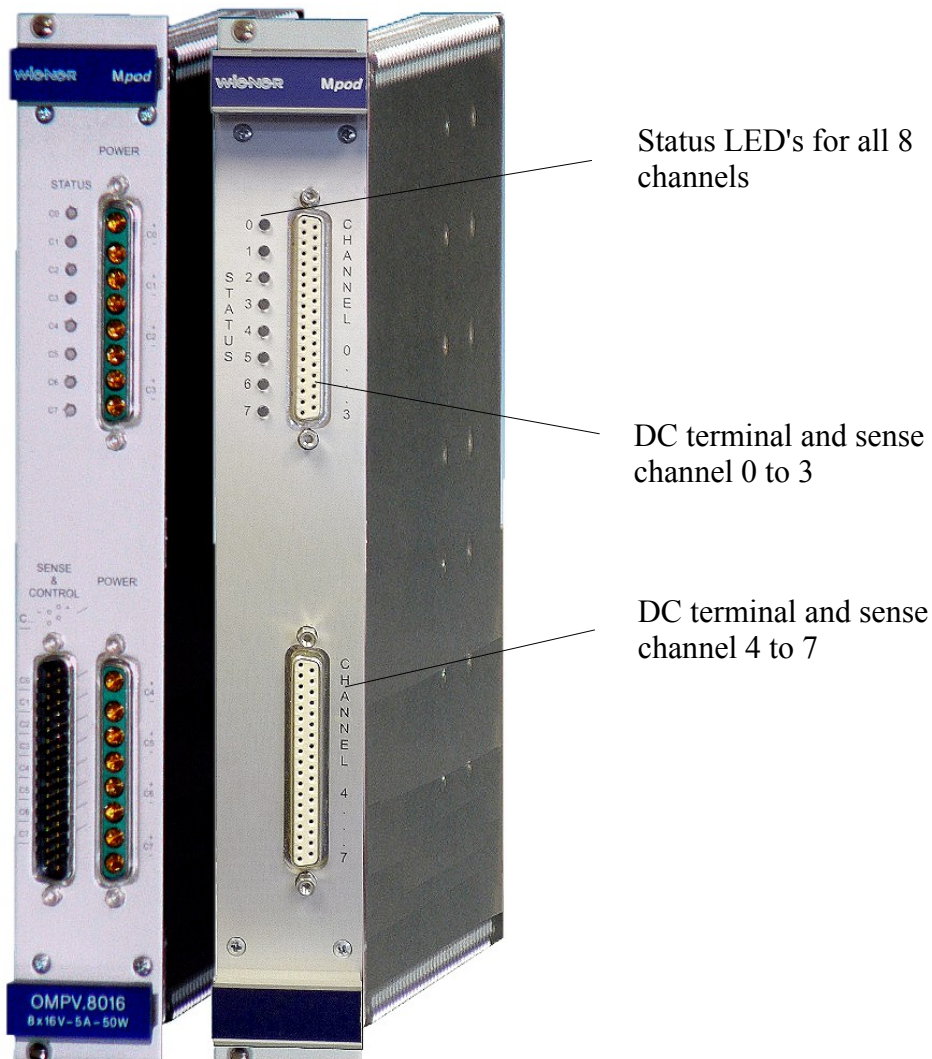

2.1 MPOD Low Voltage Module Versions

MPOD Low Voltage Series - 8 channels with floating ground

Type	Channels	Voltage	I Max	Peak Power	V-Res	I-Res	Ripple
MPV 4008I	4	0 to 8V	20A	100W / ch.	0.5mV	1mA	<3mVpp
MPV 4016I	4	0 to 15V	10A	100W / ch.	1mV	0.5mA	<2mVpp
MPV 4030I	4	0 to 30V	5A	100W / ch.	2mV	0.52mA	<2mVpp
MPV 4060I	4	0 to 60V	2A	100W / ch.	4mV	0.12mA	<2mVpp
MPV 8008D	8	0 to 8V	10A	50W / ch.	0.5mV	0.5mA	<3mVpp
MPV 8008I	8	0 to 8V	10A	50W / ch.	0.5mV	0.5mA	<3mVpp
MPV 8008LD	8	0 to 8V	5A	40W / ch.	0.5mV	0.25mA	<3mVpp
MPV 8008LI	8	0 to 8V	5A	40W / ch.	0.5mV	0.25mA	<3mVpp
MPV 8016D	8	0 to 15V	5A	50W / ch.	1mV	0.25mA	<2mVpp
MPV 8016I	8	0 to 15V	5A	50W / ch.	1mV	0.25mA	<2mVpp
MPV 8030D	8	0 to 30V	2.5A	50W / ch.	2mV	0.12mA	<2mVpp
MPV 8030I	8	0 to 30V	2.5A	50W / ch.	2mV	0.12mA	<2mVpp
MPV 8060D	8	0 to 60V	1A	50W / ch.	4mV	0.06mA	<2mVpp
MPV 8060I	8	0 to 60V	1A	50W / ch.	4mV	0.06mA	<2mVpp
MPV 8120D	8	0 to 120V	100mA	50W / ch.	4mV	4 µA	<2mVpp
MPV 8120I	8	0 to 120V	100mA	50W / ch.	4mV	4 µA	<2mVpp
MPV 8120LD	8	0 to 120V	16mA	50W / ch.	4mV	4 µA	<2mVpp
MPV 8120LI	8	0 to 120V	16mA	50W / ch.	4mV	4 µA	<2mVpp

L = Low current;

D = Sub **D** 37 pin female connector;

I = Interlock, with sub **D** 37 pin female connector.

MPOD Low Voltage mating connectors

Sub-D 37 male connector	8	4-channel combined power/sense Sense for 8 channels
Sub-D 8 female (high current)	8	Special version with 40A contacts
Sub-D 37 extension cable 5m	37	Combined power/sense for 4 channels
Sub-D 37 extension cable 25m	37	Combined power/sense for 4 channels

Connectors are **IEC807-3/DIN41652** conform. Custom made cable sets are available on request.

2.2 Combined Power & Sense Connector 8 channel modules (standard female type)

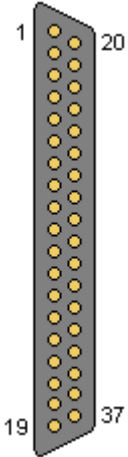
DSUB37 female (Channel 0..3)	Pin	Signal	TOP Connector
	1	U0-	Channel 0 negative output
	20	U0+	Channel 0 positive output
	2	U0-	Channel 0 negative output
	21	U0+	Channel 0 positive output
	3	U0-	Channel 0 negative output
	22	U0+	Channel 0 positive output
	4	S0-	Channel 0 negative sense input
	23	S0+	Channel 0 positive sense input
	5	U1-	Channel 1 negative output
	24	U1+	Channel 1 positive output
	6	U1-	Channel 1 negative output
	25	U1+	Channel 1 positive output
	7	U1-	Channel 1 negative output
	26	U1+	Channel 1 positive output
	8	S1-	Channel 1 negative sense input
	27	S1+	Channel 1 positive sense input
	9	U2-	Channel 2 negative output
	28	U2+	Channel 2 positive output
	10	U2-	Channel 2 negative output
29	U2+	Channel 2 positive output	
11	U2-	Channel 2 negative output	
30	U2+	Channel 2 positive output	
12	S2-	Channel 2 negative sense input	
31	S2+	Channel 2 positive sense input	
13	U3-	Channel 3 negative output	
32	U3+	Channel 3 positive output	
14	U3-	Channel 3 negative output	
33	U3+	Channel 3 positive output	
15	U3-	Channel 3 negative output	
34	U3+	Channel 3 positive output	
16	S3-	Channel 3 negative sense input	
35	S3+	Channel 3 positive sense input	
17	INTERLOCK0	Optional interlock input: The four channels of this connector are enabled only if a signal is applied here	
36	INTERLOCK1	Optional interlock input: The four channels of this connector are enabled only if a signal is applied here	
18	LOOP0	Safety Loop, LOOP0 and LOOP1 are connected to each other, no connection to other potentials	
37	LOOP1	Safety Loop, LOOP0 and LOOP1 are connected to each other, no connection to other potentials	
19	CHASSIS	Connected to chassis / front panel	

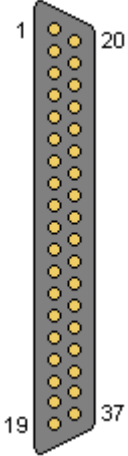
DSUB37 female (Channel 4..7)	Pin	Signal	Bottom Connector
	1	U4-	Channel 4 negative output
	20	U4+	Channel 4 positive output
	2	U4-	Channel 4 negative output
	21	U4+	Channel 4 positive output
	3	U4-	Channel 4 negative output
	22	U4+	Channel 4 positive output
	4	S4-	Channel 4 negative sense input
	23	S4+	Channel 4 positive sense input
	5	U5-	Channel 5 negative output
	24	U5+	Channel 5 positive output
	6	U5-	Channel 5 negative output
	25	U5+	Channel 5 positive output
	7	U5-	Channel 5 negative output
	26	U5+	Channel 5 positive output
	8	S5-	Channel 5 negative sense input
	27	S5+	Channel 5 positive sense input
	9	U6-	Channel 6 negative output
	28	U6+	Channel 6 positive output
	10	U6-	Channel 6 negative output
29	U6+	Channel 6 positive output	
11	U6-	Channel 6 negative output	
30	U6+	Channel 6 positive output	
12	S6-	Channel 6 negative sense input	
31	S6+	Channel 6 positive sense input	
13	U7-	Channel 7 negative output	
32	U7+	Channel 7 positive output	
14	U7-	Channel 7 negative output	
33	U7+	Channel 7 positive output	
15	U7-	Channel 7 negative output	
34	U7+	Channel 7 positive output	
16	S7-	Channel 7 negative sense input	
35	S7+	Channel 7 positive sense input	
17	INTERLOCK0	Optional interlock input: The four channels of this connector are enabled only if a signal is applied here	
36	INTERLOCK1	Optional interlock input: The four channels of this connector are enabled only if a signal is applied here	
18	LOOP0	Safety Loop, LOOP0 and LOOP1 are connected to each other, no connection to other potentials	
37	LOOP1	Safety Loop, LOOP0 and LOOP1 are connected to each other, no connection to other potentials	
19	CHASSIS	Connected to chassis / front panel	

2.3 Combined Power & Sense Connector 4 channel modules (DSUB4W17 type)

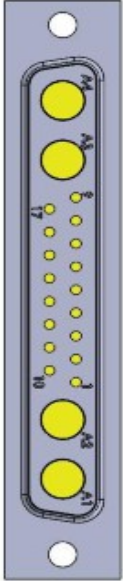
DSUB4W17 female (Channel 0+1)	Pin	Signal	Top Connector
	A4	U0+	Channel 0 positive output
	A3	U0-	Channel 0 negative output
	9	S0+	Channel 0 positive sense input
	17	S0-	Channel 0 negative sense input
	13	CHASSIS	Connected to chassis / front panel
	14	INTERLOCK1	Optional interlock input: The two channels of this connector are
	6	INTERLOCK0	enabled only if a signal is applied here
	5	LOOP1	Safety Loop, LOOP0 and LOOP1 are connected to each other, no
	4	LOOP0	connection to other potentials
	10	S1+	Channel 1 positive sense input
	1	S1-	Channel 1 negative sense input
	A2	U1+	Channel 1 positive output
	A1	U1-	Channel 1 negative output

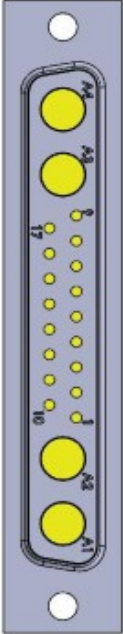
SUB37 female (Channel 2+4)	Pin	Signal	Bottom Connector
	A4	U2+	Channel 4 positive output
	A3	U2-	Channel 4 negative output
	9	S2+	Channel 4 positive sense input
	17	S2-	Channel 4 negative sense input
	13	CHASSIS	Connected to chassis / front panel
	14	INTERLOCK1	Optional interlock input: The four channels of this connector are
	6	INTERLOCK0	enabled only if a signal is applied here
	5	LOOP1	Safety Loop, LOOP0 and LOOP1 are connected to each other, no
	4	LOOP0	connection to other potentials
	10	S3+	Channel 5 positive sense input
	1	S3-	Channel 5 negative sense input
	A2	U3+	Channel 5 positive output
	A1	U3-	Channel 5 negative output

2.4 Sense & Control Connector Pin Assignment (old modules with mixed DSUB37 + DSUB37-8)

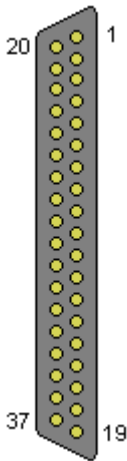
DSUB37 male (Channel 0..7)	Pin	Signal	Comment
	1	S0+	Channel 0 positive Sense Input
	20	S0-	Channel 0 negative Sense Input
	2		reserved
	21		reserved
	3	S1+	Channel 1 positive Sense Input
	22	S1-	Channel 1 negative Sense Input
	4		reserved
	23		reserved
	5	S2+	Channel 2 positive Sense Input
	24	S2-	Channel 2 negative Sense Input
	6		reserved
	25		reserved
	7	S3+	Channel 3 positive Sense Input
	26	S3-	Channel 3 negative Sense Input
	8		reserved
	27		reserved
	9	S4+	Channel 4 positive Sense Input
	28	S4-	Channel 4 negative Sense Input
	10		reserved
29		reserved	
11	S5+	Channel 5 positive Sense Input	
30	S5-	Channel 5 negative Sense Input	
12		reserved	
31		reserved	
13	S6+	Channel 6 positive Sense Input	
32	S6-	Channel 6 negative Sense Input	
14		reserved	
33		reserved	
15	S7+	Channel 7 positive Sense Input	
34	S7-	Channel 7 negative Sense Input	
16		reserved	
35		reserved	
17		reserved	
36		reserved	
18		reserved	
37		reserved	
19		reserved	

Some pins are reserved for future functionality.

2.5 Power Connector Pin Assignment (old modules with mixed DSUB37 + DSUB37-8)

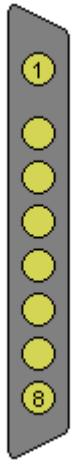
DSUB37-8 female (Channel 0..3)	Pin	Signal	Comment
	1	U0+	Channel 0 positive Output
	2	U0-	Channel 0 negative Output
	3	U1+	Channel 1 positive Output
	4	U1-	Channel 1 negative Output
	5	U2+	Channel 2 positive Output
	6	U2-	Channel 2 negative Output
	7	U3+	Channel 3 positive Output
	8	U3-	Channel 3 negative Output

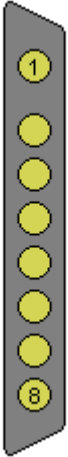
DSUB37-8 female (Channel 4..7)	Pin	Signal	Comment
	1	U4+	Channel 4 positive Output
	2	U4-	Channel 4 negative Output
	3	U5+	Channel 5 positive Output
	4	U5-	Channel 5 negative Output
	5	U6+	Channel 6 positive Output
	6	U6-	Channel 6 negative Output
	7	U7+	Channel 7 positive Output
	8	U7-	Channel 7 negative Output

Matching cable plug:

e.g. Erni TMC – P - 8W8 male, unloaded connector (103448) + pins:

<http://www.erni.com/DB/PDF/TMC/ERNI-D-SubHighPower0101-e.pdf>

2.6 SAFETY LOOP and optional INTERLOCK functionality of MPV modules

The SAFETY LOOP pins provide a closed connection between LOOP0 and LOOP1 in case the properly wired DSUB37 connector is plugged into the MPV module. It does not have any functionality inside the module!

The Interlock features is only available on MPV 8xxxI modules. Older or other modules that do not have the "I" (interlock) in the part number / name, will not interlock. Furthermore the interlock will work on the bank of 4 channels on each sub-d 37 pin connector.

Using a 5-14V source, apply +V to pin 36 and 0V to pin 17 of the MPOD module sub-d 37 pin connector (see pin layout in chapter 2.2).

In order to use the Interlock function each channel has to be enabled for this. In MUSEcontrol Software, right mouse click on the channel and check in the "Output Configuration" window the check mark "Enable External Inhibit" accordingly.

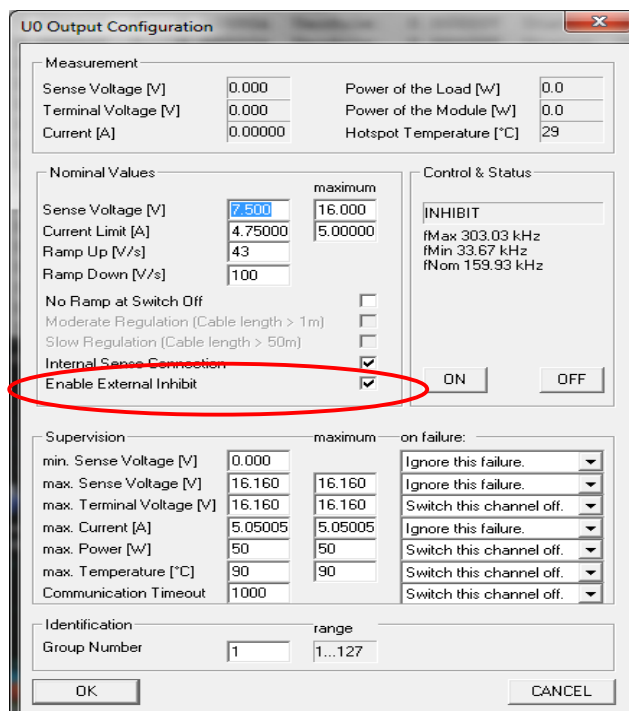

3 HV Modules

MPOD high voltage modules are manufactured by ISEG (www.iseg-hv.com). For technical details please refer to the ISEG manuals and data sheets of the EHS, EBS, EDS and EHQ (discontinued) multi channel high voltage modules. General features are:

- High Voltage modules with 4, 8, 16, 24, 32 or 48 individually controlled channels
- Maximum voltage range from 500V up to 10 kV
- Extremely low noise and ripple: <5mVpp to <10mVpp
- All DC outputs floating or common ground depending on module type
- Voltage and current settings / monitoring for each channel, 16 to 21 bit resolution
- Current monitoring and limiting for each channel, 16 to 21 bit resolution
- Programmable channel parameters, group features
- output connectors:

8 channel modules	SHV or REDEL (<4kV) multi pin Kings for 8kV and 10kV (4 channels only)
16 channel modules	SHV or REDEL (<4kV) multi pin
24 channel modules	REDEL (<4kV) multi pin or AMP 201311-3
32 channel modules	REDEL multi pin
48 channel modules	REDEL multi-pin



ISEG high voltage modules with 4 channels KINGS (10kV), 8 and 16 channels SHV, and 8 / 16 channels REDEL multi-pin connectors (from left to right)

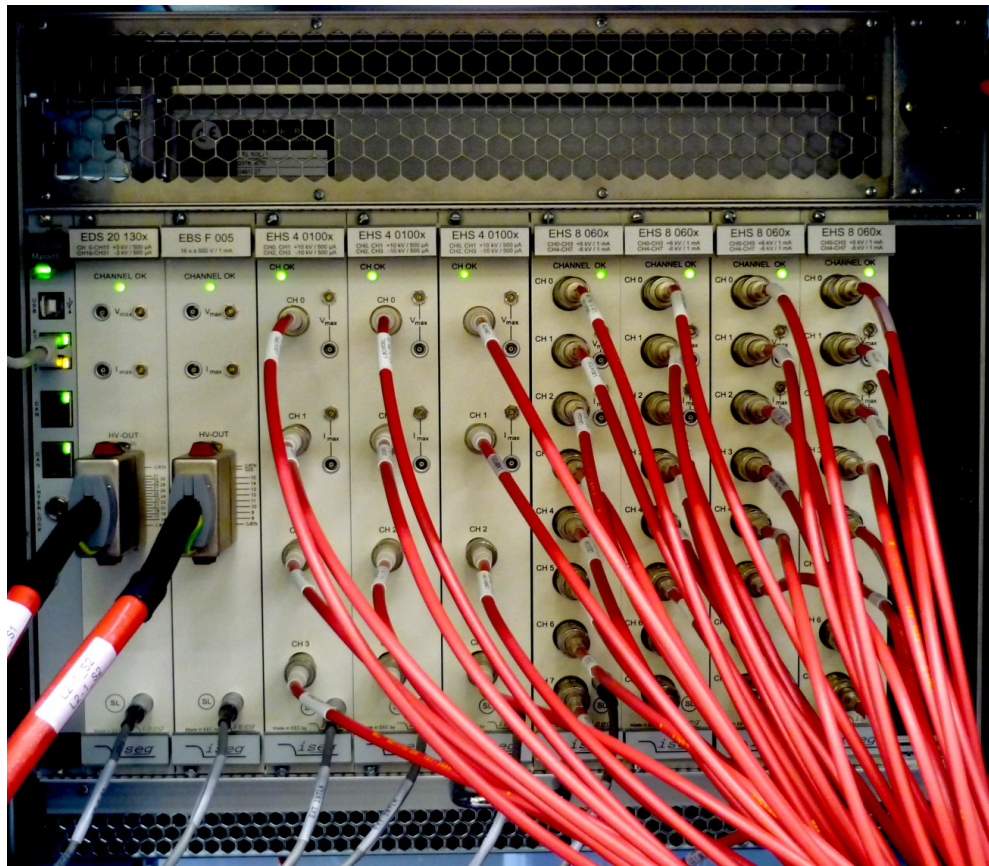

MPOD crate with rear side module option and air filter outfitted with ISEG EDS, EBS and EHS high voltage modules and wired safety loop.

4 MPOD Controller

The MPOD controller which is plugged into the first half slot of the crate controls the primary power supply as well as all inserted LV- and HV- modules. Further it connects these to remote controlling interfaces / services in a unique way.

MPOD Controller features:

- TCP/IP 10M/100M port, auto ranging
- Built-in HTTP server
- TCP/IP protocol with SNMP v.2c for full control of all module parameters
- 2 CAN-Bus ports, wired in parallel for daisy-chaining
- USB 2 interface
- 3 status LED's
- Interlock connector (9pin DSUB)

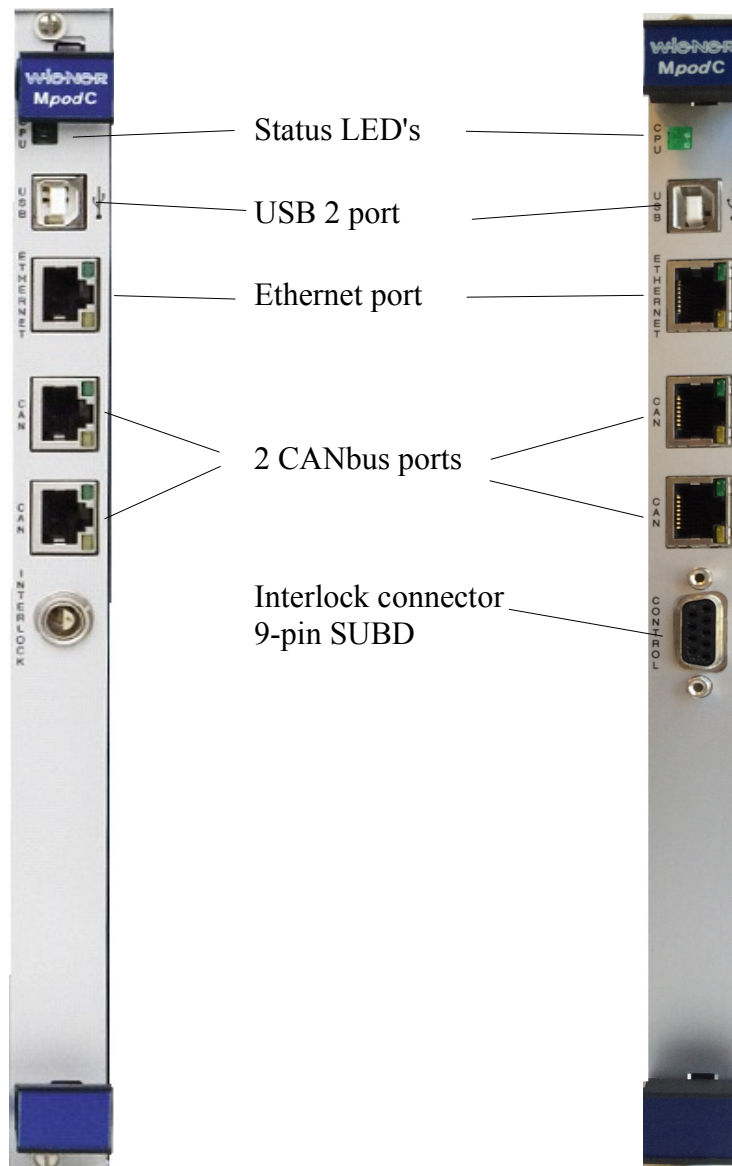

Old Controller

New Controller

Ethernet port, standard NIC pin layout

RJ45	Pin	Signal	Comment
	1	TX+	
	2	TX-	
	3	RX+	
	4	GND 1	75 Ohm
	5	GND 1	
	6	RX-	
	7	GND 2	75 Ohm
	8	GND 2	

CAN-bus ports

RJ45	Pin	Signal	Comment
	1	CAN-H	
	2	CAN-L	
	3	GND	
	4	n.c.	
	5	n.c.	
	6	reserved	
	7	GND	
	8	n.c.	

Interlock connector

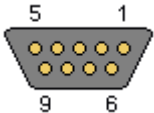
DSUB9 female	Pin	Signal	Comment
	1	CRATE_ENABLE	TTL input (1 kOhm resistor to GND) A high level allows the channels to be switched on by software A low level forces all channels to switch off with their specified down ramp.
	2	CRATE_FAST_OFF	TTL input (1 kOhm resistor to GND) A high level forces all channels to switch off as fast as possible. Any ramp-down settings are ignored.
	3	reserved	
	4	reserved	
	5	GND	Ground reference
	6	CRATE_STATUS	TTL output (1 kOhm resistor to GND, 100 Ohm resistor to protect the output buffer) This signal is driven high, if one or more channels of the MPOD system do have a non-zero output voltage
	7	reserved	
	8	reserved	
	9	(TTL High)	TTL high reference (only for FW 2.1.3079.1 and higher)

For set-up of Interlock please use MUSEcontrol in admin mode and enable / disable the Interlock by removing or setting the flag "IGNORE HARDWARE INTERLOCK" in the configuration tab.

5 Local Control

5.1 Introduction

MPOD full size and MPOD mini crates can be optionally equipped with a local color graphic display and two rotary controls.

5.2 Usage of the rotary controls

Please note that the display function and operation changed with MOD firmware 1.1.2021. Connecting MPOD to the AC line will show the following screen:

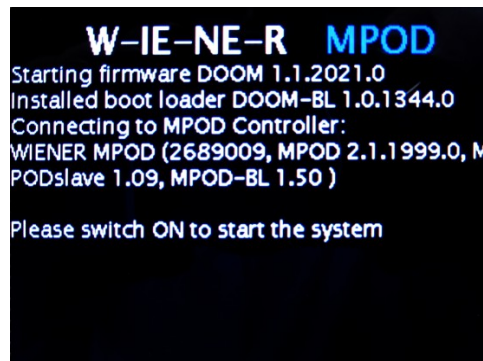

Switching POWER on (green ON/OFF) will power up the MPOD crate and the display will scan the crate for available module.

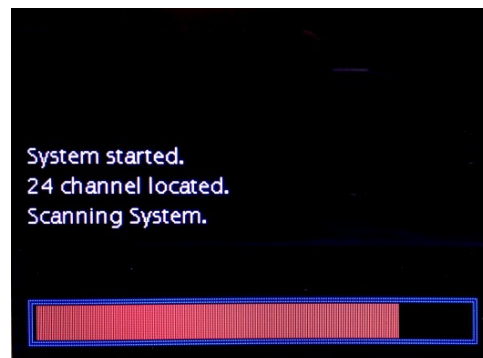
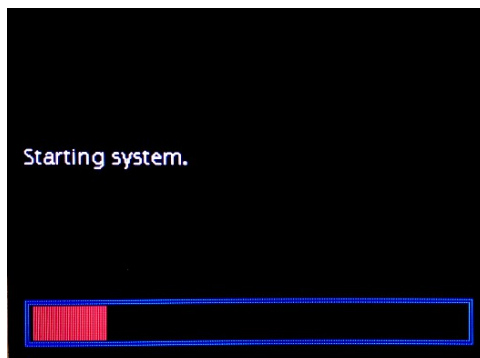

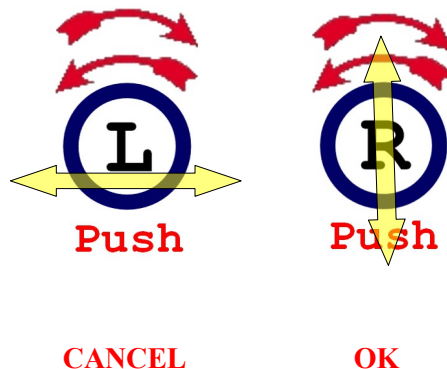

The two rotary knobs can be rotated and pushed. The right one controls vertical selections (e.g. to scroll down a menu task or increase/decrease a operating value), while the left one controls the horizontal selections (e.g. select other menus or sub-menus). By pushing the right knob (OK) it is possible to select a menu item or to confirm input. By pushing the left knob (CANCEL) it is possible to escape from input fields.

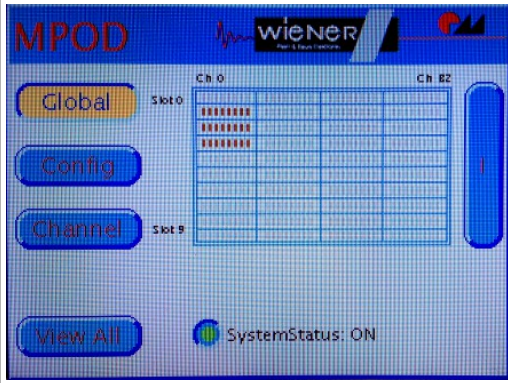
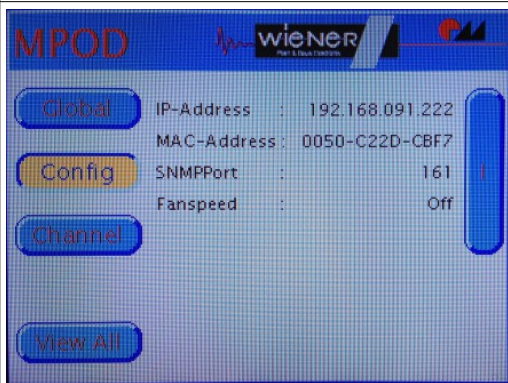

All selected menu-items are colored in yellow, data to be changed are shown in red color.

5.3 MPOD Display Main menu

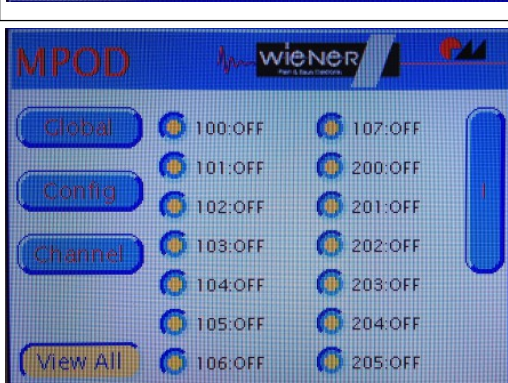
	<p>GLOBAL Window</p> <ul style="list-style-type: none"> • Rotate <R> to change between GLOBAL, CONFIG, CHANNEL and VIEW ALL
	<p>CONFIG Window</p> <ul style="list-style-type: none"> • Press <R> or turn <L> to the right to enter menu to change network settings and fan speed • Rotate <R> to change between GLOBAL, CONFIG, CHANNEL and VIEW ALL •
	<p>Channel Window</p> <ul style="list-style-type: none"> • Press <R> or turn <L> to the right to enter menu to access power supply channels • Rotate <R> to change between GLOBAL, CONFIG, CHANNEL and VIEW ALL
	<p>VIEW ALL Window</p> <ul style="list-style-type: none"> • Press <R> or turn <L> to the right to go into screen saver mode with high visibility channel display • Rotate <R> to change between GLOBAL, CONFIG, CHANNEL and VIEW ALL

5.4 MPOD Display CHANNEL menu

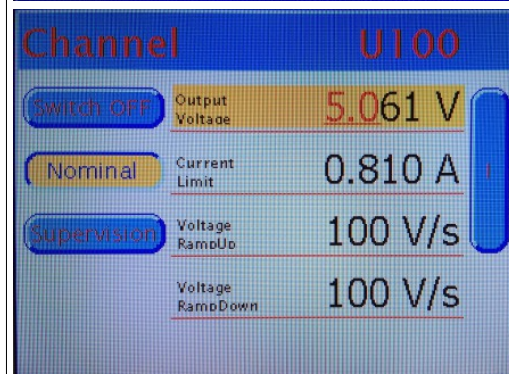
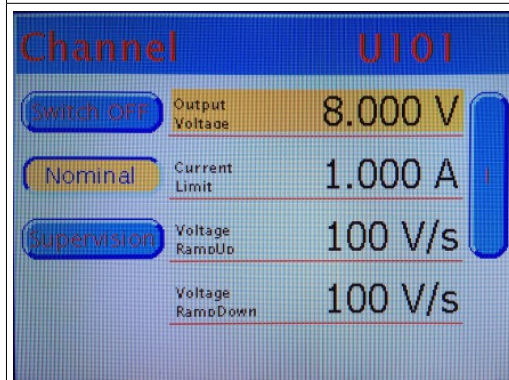
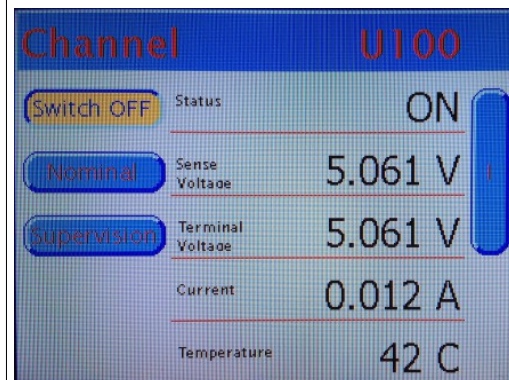
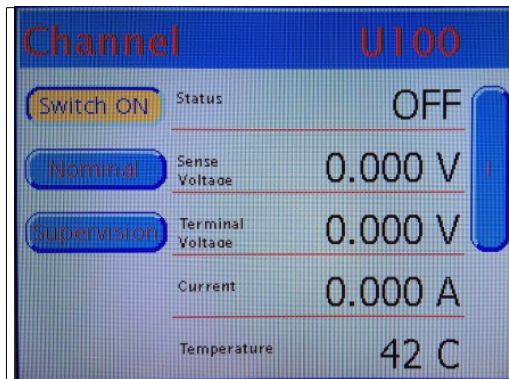

SWITCH ON / OFF and status Window

- Press **<R>** to switch channel ON or OFF
- Rotate **<R>** to change between **SWITCH ON/OFF**, **NOMINAL** and **SUPERVISION**
- Rotate **<L>** to go back (left) or to select another channel (right) which will mark right button yellow, channel then can be changed with **<R>**

NOMINAL settings Window

- Press **<R>** to select parameter (will be marked yellow)
- Rotate **<R>** to change between **Output Voltage**, **Current Limit** or **Voltage ramps**
- Press **<R>** to edit value (will be shown in red), change value with **<R>**, **<L>** will change resolution digits (red) to allow precise settings
- Press **<R>** save new values or **<L>** to discard (cancel)
- Rotate **<L>** to go back (left) or to select another channel (right) which will mark right button yellow, channel then can be changed with **<R>**

Channel		U101
Switch ON	min.Sense Voltage	0.000 V
Nominal	max.Sense Voltage	8.000 V
Supervision	max.Term Voltage	8.000 V
	max. Current	5.050 A
	max. Power	50 W

Channel		U101
Switch ON	min.Sense Voltage	0.000 V
Nominal	max.Sense Voltage	8.000 V
Supervision	max.Term Voltage	8.000 V
	max. Current	5.050 A
	max. Power	50 W

Supervision settings Window (only MPV8xxx)

- Press **<R>** to select parameter (will be marked yellow)
- Rotate **<R>** to change between parameters
- Press **<R>** to edit value (will be shown in red), change value with **<R>**, **<L>** will change resolution digits (red) to allow precise settings
- Press **<R>** save new values or **<L>** to discard (escape)
- Rotate **<L>** to go back (left) or to select another channel (right) which will mark right button yellow, channel then can be changed with **<R>**

5.5 MPOD Display Key-lock function

The Key-lock function is a protection feature for the MPOD display. The display control can either be in "locked" or "unlocked" state. The "Lock/Unlock-Button" in the main menu shows the current state. None of the MPOD and Power Module options can be modified in Local Control via MPOD Display when the crate is in the locked state. It is still possible to change options over Ethernet.

- The key and the lock state will be saved even after unplugging the power cable.
- Flashing a new firmware resets the key.
- The key is "0" by default.

5.5.1 Lock the System

The button in the main menu displays the text "Lock". Highlight the button by rotating **<R>** and confirm with pressing **<R>** for activation. The system is now locked. The button changes color from blue to red when the state is locked.

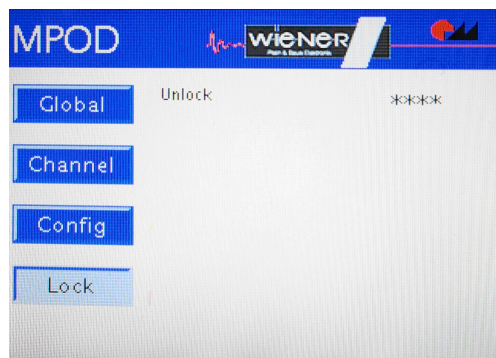

5.5.2 Unlock the System

The button in the main menu displays the text "Unlock". Highlight the button by rotating <R> and confirm with pressing <R> for activation. Press <R> again to control the number box "Unlock" on the right side. Rotate <R> to the right to increase the current number. Rotate <R> to the left to decrease the number. The rotation of <L> controls the position of the cursor. Enter the unlock key and press <R> again to unlock the system.

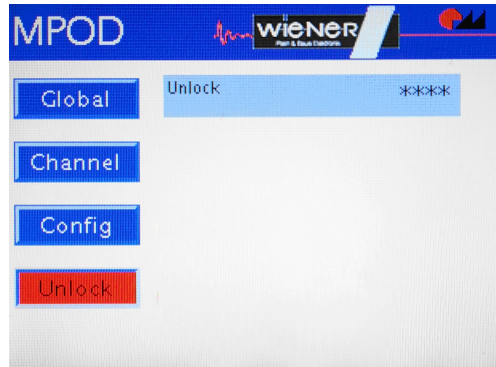

5.5.3 Change the Key

The key can be changed in the "Config -> Keylock" menu.

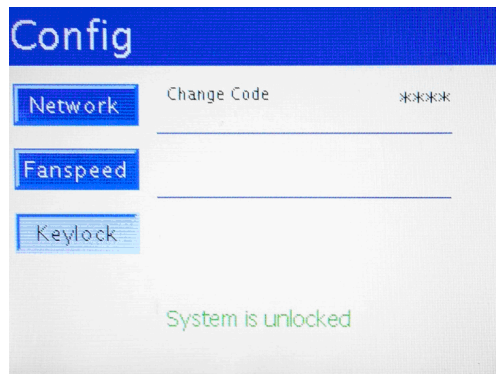

Press <R> on the "Keylock" button to access the box "Change Code" for changing the key. Hit <R> again to control the numbers.

The procedure for changing the key consists of three steps. An additional status message is displayed on the bottom of the screen.

1. Enter the old key and confirm with the <R> button.
2. Enter the new key that will be used for unlocking the system. Confirm with <R>. Numbers from 0 to 9999 are possible.
3. Enter the new key again and hit <R>. The key is now changed. If the entered key differs from the key entered in step 2, please type in the new key again.

The procedure can be canceled every time by pressing the <L> button.

6 Remote Control / Software

Please check the download section at file.wiener-d.com for the latest version of MPOD software and documentation!

6.1 MUSEcontrol Software Microsoft Windows

6.1.1 Software Installation

Before the MPOD Controller can be used, it may have to be configured according to the network environment. The factory default configuration is DHCP.

This is done locally via display or by running the MUSEcontrol utility, which allows access via the USB-port of the MPOD Controller with a computer running 32/64-bit Windows XP, VISTA or Windows 7/8.

Please download the latest program version from the file server at file.wiener-d.com. Run the MUSEcontrolInstall program to install all drivers and the program itself. It is recommended to define a short path for the driver location during installation. Connecting the MPOD Controller via USB it should be automatically detected and the Silicon Labs USB drivers (SiLib.sys and SiUSBXp.sys) loaded

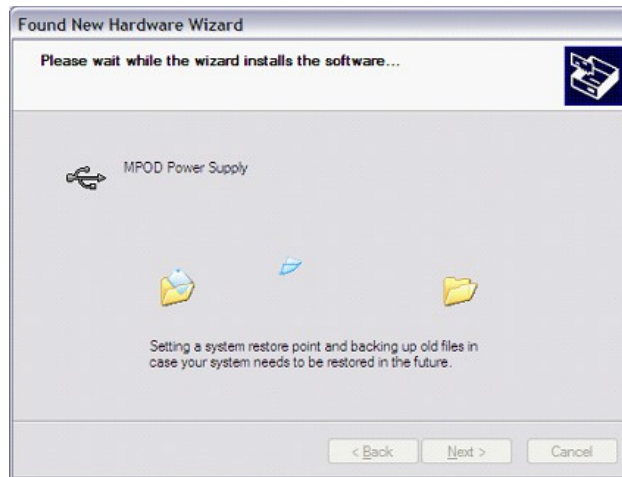

6.1.2 First Start

Starting the program, the main window gives a quick overview of the MPOD and its connected MPV low voltage modules.

Please note that the MPOD crate has to be switched on in order to show the low voltage modules!

File	Switch...	SelectOutput	DVM	OutputConfiguration	OutputCalibration	System	Stop	Help
U4	Usense:	3.000W	I: -0.005A	Umodule:	3.165V	Status: ON		
U5	Usense:	3.999W	I: -0.004A	Umodule:	4.219V	Status: ON		
U6	Usense:	5.001W	I: 0.009A	Umodule:	5.274V	Status: ON		
U7	Usense:	5.999W	I: -0.006A	Umodule:	6.330V	Status: ON		

In case no MPV low voltage modules are located in the crate an error message “No module found” will pop up which should be ignored.

Note, all ISEG high voltage modules will not be shown in MUSEcontrol and can not be controlled via USB! Please use the ethernet port and communication for this purpose.

6.1.3 Network Setup / Configuration

To prepare the MPOD controller select System → Configuration which starts the network configuration dialog as shown below. Here you enter the TCP/IP network settings (IP address, subnet mask and default gateway). You have to use the parameters of your local network here. Please contact your network administrator for details. In order to use DHCP (factory default) an I address of 0.0.0.0 has to be selected. IP address of 0.0.0.0 will enable DHCP.

HTTP and SNMP port numbers should only be modified if you know what you do. Setting any ports to 0 disables the server.

The “First LV Slot” item is only used on old systems / FW versions to define the slot number of the first LV-module. Any HV-module plugged into this slot will not be detected. (This setting is necessary only for older MPOD firmware versions and older MPV modules without automatic detection of their slot numbers)

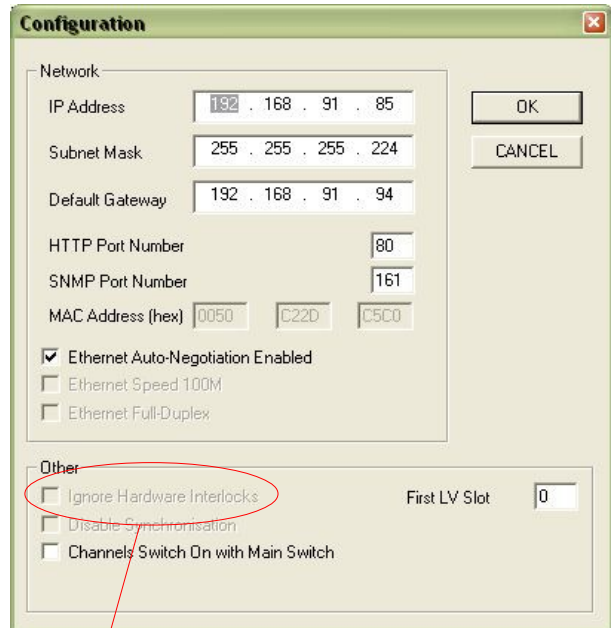

6.1.4 Enable / Disable MPOD controller interlock

Run MUSEcontrol program in admin mode:

"C:\Program Files\W-IE-NE-R\MUSEcontrol\MUSEcontrol.exe" USB 0x224

- **Disable Interlock** (Default): check mark “**Ignore Hardware interlock**” should be set
- **Enable Interlock** : remove check mark “**Ignore Hardware interlock**”

6.1.5 MPOD Controller Firmware Updates

Another essential menu item is the System → FirmwareUpdate which starts the firmware update (see appendix A). The latest recommended MPOD Firmware and Boot loader can be found at file.wiener-d.com. Instructions for the firmware upgrade are given in chapter 12.

6.1.6 WIENER MPV8xxx and MPV4xxx Operation

Low Voltage channels can be completely programmed and monitor within the MUSE application. You can switch on or off any channel by clicking at the line of the channel. If you click with the right mouse button, the “OutputConfiguration” dialog is entered:

The dialog is divided into five main sections:

- **Measurement**
Shows the actual measured sense voltage, terminal voltage (at the module terminals), current, the calculated power and the most critical module temperature.
- **Control & Status**
Here the channel can be switched on and off. If the channel has switched off because of any failure, the reason is displayed here, too.
- **Nominal Values**
Here the nominal output voltage (sense voltage), current limit and ramping speeds are entered. The “No Ramp at Switch Off” check box forces immediate switch off. The

regulation mode can be optimized for different cable lengths (slow regulation requests both check boxes to be checked!)

- **Supervision**

Here the threshold values of the minimum sense voltage, the maximum sense voltage, the maximum terminal voltage, the maximum current, the maximum power, the maximum temperature and the communication timeout can be entered. The right column “maximum” can only be changed by this utility and is the maximum allowed value of the left column. The left column may be changed here or via the TCP/IP network.

The most right column “on failure” defines the action if the associated threshold is exceeded.

The “communication timeout” at the last row is an internal timeout of the communication between different processors. If the processor responsible for a specific output has no data from it's master processor for longer than this time (in milliseconds), the output channel will be switched off.

- **Identification**

Here the group number of this channel can be entered.

Other main menu items associated with this dialog are “Start/Stop” (stop and restart the communication with the MPOD controller via USB) and “SelectOutput”, which simple increments the channel number which is displayed by the other dialogs.

The other main menu items are used for test and maintenance and should not used by the customer.

6.2 Web Browser

With a web browser pointing to the IP address as URL it is possible to get an overview of all channels in a simple way.

Global Status

Mainframe Status	ON
------------------	----

Output Channels

Channel	Voltage	Current	Measured Sense Voltage	Measured Current	Measured Terminal Voltage	Status
U 4	3000.0 mV	5000.0 mA	2999.5 mV	-5127.0 uA	3164.6 mV	ON
U 5	4000.0 mV	5000.0 mA	3999.0 mV	-3906.3 uA	4218.8 mV	ON
U 6	5000.0 mV	5000.0 mA	5001.5 mV	8.545 mA	5273.9 mV	ON
U 7	6000.0 mV	5000.0 mA	5999.0 mV	-5371.1 uA	6330.1 mV	ON
U500	101.00 V	6000.0 uA	100.98 V	0 A	100.98 V	ON
U501	152.00 V	6000.0 uA	151.99 V	0 A	151.99 V	ON
U502	103.00 V	6000.0 uA	103.05 V	0.0 uA	103.05 V	ON
U503	154.00 V	6000.0 uA	154.03 V	0 A	154.03 V	ON
U504	105.00 V	6000.0 uA	104.61 V	0 A	104.61 V	ON
U505	156.00 V	6000.0 uA	155.78 V	0.1 uA	155.78 V	ON
U506	107.00 V	6000.0 uA	106.97 V	0 A	106.97 V	ON
U507	152.00 V	6000.0 uA	152.14 V	0 A	152.14 V	ON
U508	0 V	6000.0 uA	0 V	0 A	0 V	OFF
U509	0 V	6000.0 uA	0 V	0 A	0 V	OFF
U510	0 V	6000.0 uA	0 V	0 A	0 V	OFF
U511	0 V	6000.0 uA	0 V	0 A	0 V	OFF
U512	0 V	6000.0 uA	193.20 mV	0 A	193.20 mV	OFF
U513	0 V	6000.0 uA	0 V	0 A	0 V	OFF
U514	0 V	6000.0 uA	0 V	0 A	0 V	OFF
U515	0 V	6000.0 uA	0 V	0 A	0 V	OFF

6.3 NetSNMP

NetSNMP is an open source SNMP program which can be used to access the MPOD controller via the Simple Network Management Protocol. Please see <http://net-snmp.sourceforge.net/> for more details.

Please install netSNMP (32-bit version) from the CD-ROM or downloaded from WIENER support web site on the control computer. In order to perform SNMP calls from any WIENER product the WIENER-CRATE-MIB file must be stored somewhere on the PC doing the calls, by default that location should be /usr/share/snmp/mibs (Windows: C:\usr\share\snmp\mibs).

6.3.1 SNMP commands and community groups

The most commonly used net-snmp calls are:

- snmpwalk** – returns groups of parameters / items
- snmpget** – returns a specific parameter (read)
- snmpset** – sets a specific parameter (write)

Please see the Net-snmp description and help files for detailed instructions and options. All parameters defined for the WIENER MPOD system as well as crates and other power supplies are contained within the WIENER-CRATE-MIB.txt file (see description in there!).

The following community groups are used:

- “**public**”: for all read operations
- “**private**”: to switch crate on or off
- “**admin**”: to change parameters as fan speed or temperature limits
- “**guru**”: to change HV and LV channel parameters as voltages, current limits, ramps, ...

A fast and easy way to begin using SNMP is to use command line arguments. The command line arguments specified in this document are based on netSNMP. The command line syntax is the same for both windows and Linux (and probably MAC OSX).

6.3.2 SNMP command help

For all WIENER-CRATE-MIB library calls a quick help text can be shown by using

```
snmptranslate -On -Td WIENER-CRATE-MIB::xxxx
```

```
snmptranslate -On -Td WIENER-CRATE-MIB::outputName
```

```
.1.3.6.1.4.1.19947.1.3.2.1.2
```

```
outputName OBJECT-TYPE
```

```
-- FROM WIENER-CRATE-MIB
```

```
-- TEXTUAL CONVENTION DisplayString
```

```
SYNTAX OCTET STRING (1..4)
```

```
DISPLAY-HINT "255a"
```

```
MAX-ACCESS read-only
```

```
STATUS current
```

```
DESCRIPTION "A textual string containing a short name of the  
output. If the crate is equipped with an alphanumeric  
display, this string is shown to identify a output channel."
```

```
::= { iso(1) org(3) dod(6) internet(1) private(4) enterprises(1) wiener(19947) c  
rate(1) output(3) outputTable(2) outputEntry(1) 2 }
```

Please note that WIENER and ISEG are continuously improving the SNMP communication and as a result new features may be added. In case of questions please always check the current functionality of a particular SNMP parameter with snmptranslate as shown above!

6.3.3 Basic SNMP communication and channel control

A first communication with the MPOD crate can be done using the snmpwalk to confirm the existence of the power supply at the given IP address.

```
snmpwalk -Cp -Oqv -v 2c -M $path -m +WIENER-CRATE-MIB -c public $ip
```

with:

snmpwalk: This command will retrieve a block of information.

-v 2c: This parameter specifies which version of the SNMP to use. WIENER devices use SNMP 2C.

-M \$path: This parameter should be replaced with the path to the WIENER-CRATE-MIB.txt file. It is not needed in case the default path is used.

-m +WIENER-CRATE-MIB: This parameter tells the command to look at the WIENER-CRATE-MIB to resolve the OID name.

-c public: This specifies which community of values can be accessed.

\$ip: This should be replaced with the IP address of the MPOD crate.

Example for crate with IP address 192.168.2.25:

```
snmpwalk -v 2c -m +WIENER-CRATE-MIB -c public 192.168.2.25
```

returns:

```
SNMPv2-MIB::sysDescr.0 = STRING: WIENER MPOD (4193086, MPOD 1.1.1.6,  
MPODslave 1.06)
```

SNMPv2-MIB::sysObjectID.0 = OID: WIENER-CRATE-MIB::sysMainSwitch.0
SNMPv2-MIB::sysUpTime.0 = Timeticks: (13401) 0:02:14.01
SNMPv2-MIB::sysContact.0 = STRING:
SNMPv2-MIB::sysName.0 = STRING:
SNMPv2-MIB::sysLocation.0 = STRING:
SNMPv2-MIB::sysServices.0 = INTEGER: 79

A list of all available parameters or sub-parameters as for instance channels can be obtained using the command `snmpwalk` with the parameter “crate”. To get all parameters use:

snmpwalk -Cp -Oqv -v 2c -M \$path -m +WIENER-CRATE-MIB -c public \$ip crate

example:

snmpwalk -v 2c -m +WIENER-CRATE-MIB -c public 192.168.2.25 crate

Further it is possible obtain the array of names or values for a specific parameter. The following command provides a list of all existing output channels:

snmpwalk -Cp -Oqv -v 2c -M \$path -m +WIENER-CRATE-MIB -c public \$ip outputName

Example:

snmpwalk -v 2c -m +WIENER-CRATE-MIB -c public 192.168.2.25 outputName

returns for MPOD system with 2 ISEG EHS HV modules (8 channels each) in slot 2 and 3:

WIENER-CRATE-MIB::outputName.u100 = STRING: U100
WIENER-CRATE-MIB::outputName.u101 = STRING: U101
WIENER-CRATE-MIB::outputName.u102 = STRING: U102
WIENER-CRATE-MIB::outputName.u103 = STRING: U103
WIENER-CRATE-MIB::outputName.u104 = STRING: U104
WIENER-CRATE-MIB::outputName.u105 = STRING: U105
WIENER-CRATE-MIB::outputName.u106 = STRING: U106
WIENER-CRATE-MIB::outputName.u107 = STRING: U107
WIENER-CRATE-MIB::outputName.u200 = STRING: U200
WIENER-CRATE-MIB::outputName.u201 = STRING: U201
WIENER-CRATE-MIB::outputName.u202 = STRING: U202
WIENER-CRATE-MIB::outputName.u203 = STRING: U203
WIENER-CRATE-MIB::outputName.u204 = STRING: U204
WIENER-CRATE-MIB::outputName.u205 = STRING: U205
WIENER-CRATE-MIB::outputName.u206 = STRING: U206
WIENER-CRATE-MIB::outputName.u207 = STRING: U207

This example returns 16 index numbers. Please note the following geographic module and channel number coding for the SNMP call indexes, where the first digit is defined by the slot number and the following two by the channel of the particular module in this slot:

Slot	Channel	Name	index
1	0 to 99	Uxx	.u00 to .u99
2	0 to 99	U1xx	.u100 to .u199
...
10	0 to 99	U9xx	.u901 to .u999

Please note that both the index as well as the name can be used!

snmpget -v 2c -m +WIENER-CRATE-MIB -c public 192.168.0.80 outputVoltage.u0
WIENER-CRATE-MIB::outputVoltage.u0 = Opaque: Float: 123.000000 V

is identical to

```
snmpget -v 2c -m +WIENER-CRATE-MIB -c public 192.168.0.80 outputVoltage.1  
WIENER-CRATE-MIB::outputVoltage.u0 = Opaque: Float: 123.000000 V
```

In case of multi crate system there will be an additional digit for the crate number:

```
Name = 1000 * crate + 100*slot + channel  
index = 1000 * crate + 100*slot + channel
```

(crate: 0 ... 9, slot: 0 ... 9, channel: 0 ... 99)

To see all Output channel set voltage values use snmpwalk with outputVoltage:

```
snmpwalk -Cp -Oqv -v 2c -M $path -m +WIENER-CRATE-MIB -c public $ip  
outputVoltage
```

Example:

```
snmpwalk -v 2c -m +WIENER-CRATE-MIB -c public 192.168.2.25 outputVoltage
```

returns for a MPOD system with one 8 channel ISEG EHS HV module in slot 3:

```
WIENER-CRATE-MIB::outputVoltage.u200 = Opaque: Float: 0.000000 V  
WIENER-CRATE-MIB::outputVoltage.u201 = Opaque: Float: 0.000000 V  
WIENER-CRATE-MIB::outputVoltage.u202 = Opaque: Float: 0.000000 V  
WIENER-CRATE-MIB::outputVoltage.u203 = Opaque: Float: 0.000000 V  
WIENER-CRATE-MIB::outputVoltage.u204 = Opaque: Float: 0.000000 V  
WIENER-CRATE-MIB::outputVoltage.u205 = Opaque: Float: 0.000000 V  
WIENER-CRATE-MIB::outputVoltage.u206 = Opaque: Float: 0.000000 V  
WIENER-CRATE-MIB::outputVoltage.u207 = Opaque: Float: 0.000000 V
```

After obtaining information about the power supplies or a list of channels and parameters, it is useful to be able to write or read information about it. This can be done using the **snmpget** and **snmpset** commands.

```
snmpget -Oqv -v 2c -M $path -m +WIENER-CRATE-MIB -c guru $ip name.index
```

```
snmpset -v 2c -M $path -m +WIENER-CRATE-MIB -c guru $ip name.index format value
```

The most common kind of call you will want is to get data from the power supply. This is easily done via the **snmpget** command. The example below retrieves information about whether the main power for the crate is on. If you wish to test this example on your own system replace “\$path” with the path to WIENER-CRATE-MIB.txt (/usr/share/snmp/mibs by default and “\$ip” with the ip address of your MPOD (see following examples).

```
snmpget -v 2c -M $path -m +WIENER-CRATE-MIB -c public $ip sysMainSwitch.0  
WIENER-CRATE-MIB::sysMainSwitch.0 = INTEGER: OFF(0)
```

This indicates that the MPOD crate is currently off. To better understand the call above we will break it down by parameter:

snmpget: This command will retrieve a value about the MPOD crate or one of the channels it houses..

-v 2c: This parameters specifies which version of the SNMP to use. WIENER devices use SNMP 2C.

-M \$path: This parameter should be replaced with the path to the WIENER-CRATE-MIB.txt file.

-m +WIENER-CRATE-MIB: This parameter tells the command to look at the WIENER-CRATE-MIB to resolve the OID name.

-c public: This specifies which community of values can be accessed.

Sip: This should be replaced with the IP address of the MPOD crate.

sysMainSwitch.0: This is the register you wish to retrieve.

Since we know from the call above that the crate is off, we may want to turn it on. (Software power cycling is only possible if the green mains switch on the MPOD is “ON”, this is to prevent a remote user to override a local user and adds a level of safety to the unit.) To turn MPOD on, we can use the command:

```
snmpset -v 2c -path -m +WIENER-CRATE-MIB -c private $ip sysMainSwitch.0 i 1
```

Most of the parameters for snmpset are the same as snmpget, the new parameters are highlighted below.

i: Since sysMainSwitch.0 is an integer value, we specify the value to be an integer with.

1: This is the value we wish to write. In this case we write ‘one’ to set the main switch to on.

For most of the write commands (snmpset) the access type has to be changed from public to guru.

A complete list of value names that can be written or read via SNMP can be found in the WIENER-CRATE-MIB but commonly needed values are (see full list in chapter 6.10):

Value Name	Type	Access	Comments
outputVoltage	Float	R/W	The Channel set Voltage
outputCurrent	Float	R/W	The channel current limit
outputMeasurementSenseVoltage	Float	R	Actual channel Voltage at sense line
outputMeasurementTerminalVoltage	Float	R	Actual channel Voltage at terminal
outputMeasurementCurrent	Float	R	Actual channel current
outputSwitch	Integer	R/W	Turns channel ON / OFF, emergency off, reset error flags
outputVoltageRiseRate	Float	R/W	Channel ramp rate up
outputVoltageFallRate	Float	R/W	Channel ramp rate down
outputStatus	Bits	R	Channel Status information

For example, to read channel set voltage use:

```
snmpget -Oqv -v 2c -M $path -m +WIENER-CRATE-MIB -c guru $ip outputVoltage.index
```

Example:

```
snmpget -v 2c -m +WIENER-CRATE-MIB -c public 192.168.2.25 outputVoltage.u0  
WIENER-CRATE-MIB::outputVoltage.u0 = Opaque: Float: 0.000000 V
```

Write and read individual set voltages, “guru” access needed to write!

```
snmpset -v 2c -m +WIENER-CRATE-MIB -c guru 192.168.2.25 outputVoltage.u101 F 200  
WIENER-CRATE-MIB::outputVoltage.u101 = Opaque: Float: 200.000000 V
```

Note the “F” before the 200, this indicates that the value is a floating point number. This value can be read back via:

snmpget -v 2c -m +WIENER-CRATE-MIB -c public 192.168.2.25 outputVoltage.u101
WIENER-CRATE-MIB::outputVoltage.u101 = Opaque: Float: 200.000000 V

Turning Channels ON/OFF - The individual channels of an MPOD system low or high voltage module can be turned on or off using the snmpset command. To turn on channel Ux:

snmpset -Oqv -v 2c -M \$path -m +WIENER-CRATE-MIB -c guru \$ip outputSwitch.index i 1

The same channel can be turned off with:

snmpset -Oqv -v 2c -M \$path -m +WIENER-CRATE-MIB -c guru \$ip outputSwitch.index i 0

The **outputSwitch** can also be used for emergency-off and to reset error flags. The matching values are: {off(0), on(1), resetEmergencyOff(2), setEmergencyOff(3), clearEvents(10)}

Item	Type	Access	Switch functions
outputSwitch	integer	write	Off (0) On (1) resetEmergencyOff (2) setEmergencyOff (3) clearEvents (10)

Example:

snmpset -v 2c -m +WIENER-CRATE-MIB -c guru 192.168.2.25 outputSwitch.u101 i 1

MPOD low and high voltage modules have programmable voltage ramp speeds. The WIENER low voltage modules allow different ramp up and down values for each channel whereas for ISEG modules with common ramp the channel-ID can be any channel of the module! For write access “guru” is needed:

snmpset -Oqv -v 2c -M \$path -m +WIENER-CRATE-MIB -c guru \$ip outputVoltageRiseRate.index F value

Example:

snmpset -v 2c -m +WIENER-CRATE-MIB -c guru 192.168.2.25 outputVoltageRiseRate.u101 F 10
WIENER-CRATE-MIB::outputVoltageRiseRate.u101 = Opaque: Float: 10.000000 V/s

snmpget -v 2c -m +WIENER-CRATE-MIB -c public 192.168.2.25 outputVoltageRiseRate.u101
WIENER-CRATE-MIB::outputVoltageRiseRate.u101 = Opaque: Float: 10.000000 V/s

To access multiple units the **groupsSwitch** function provides access to all modules in the MPOD crate (index 0), all ISEG HV modules (index 64), or to all WIENER low voltage modules (index 128). In addition groups can be defined for low voltage modules.

Item	Type	Access	Switch functions
groupsSwitch	integer	write	Off (0) On (1) resetEmergencyOff (2) setEmergencyOff (3) disableKill (4),

enableKill (5),
clearEvents (10)

Examples:

switch all channels of all modules on:

```
snmpset -v 2c -m +WIENER-CRATE-MIB -c guru 192.168.0.80 groupsSwitch.0 i 1  
WIENER-CRATE-MIB::groupsSwitch.0 = INTEGER: on(1)
```

switch all channels off:

```
snmpset -v 2c -m +WIENER-CRATE-MIB -c guru 192.168.0.80 groupsSwitch.0 i 0  
WIENER-CRATE-MIB::groupsSwitch.0 = INTEGER: off(0)
```

switch all high voltage channels (ISEG modules) off:

```
snmpset -v 2c -m +WIENER-CRATE-MIB -c guru 192.168.0.80 groupsSwitch.64 i 0  
WIENER-CRATE-MIB::groupsSwitch.64 = INTEGER: off(0)
```

RESET ISEG HV Modules after Safetyloop error:

```
snmpset -v 2c -m +WIENER-CRATE-MIB -c guru 192.168.0.80 groupsSwitch.64 i  
10  
WIENER-CRATE-MIB::groupsSwitch.64 = INTEGER: clearEvents(10)
```

6.3.4 Special commands for ISEG high voltage modules

Item	Type	Access	Status bits / Switch functions
outputSwitch	integer	read-write	Off (0) On (1) resetEmergencyOff (2) setEmergencyOff (3) clearEvents (10)

DESCRIPTION

Read: An enumerated value which shows the current state of the output channel.

Write: Change the state of the channel.

If the channel is On, and the write value is Off, then the channel will switch off.

If the channel is Off, and the write value is On, and if no other signals (**mainInhibit**, **outputInhibit**, **outputEmergencyOff** or **outputFailureMaxCurrent**) are active, then the channel will switch on.

If the write value is **resetEmergencyOff**, then the channel will leave the state **EmergencyOff**.

A write of **clearEvents** is necessary before the voltage can ramp up again.

If the write value is **setEmergencyOff**, then the channel will have the state **EmergencyOff**, which means that the High Voltage will switch off without a ramp and reset of the **outputVoltage** to null volt.

If the write value is **clearEvents**, then all failure messages of the **outputStatus** will be reset (all channel events, all module events and the state **EmergencyOff**).

Item	Type	Access	Switch functions
groupsSwitch.64	integer	write	Off (0), On (1)

resetEmergencyOff (2)
setEmergencyOff (3),
disableKill (4)
enableKill (5)
clearEvents (10)

DESCRIPTION

Read: This function is not defined!

Write: Switch the state of all channels of group 64 (all high voltage modules).

If any channel is On, and the write value is Off, then all channels will switch off. If any channel is Off, and the write value is On, and if no other signals (**mainInhibit**, **outputInhibit**, **outputEmergencyOff** or **outputFailureMaxCurrent**) are active, then all channels will switch on.

If the write value is **resetEmergencyOff**, then all channels will leave the state **EmergencyOff**. A write of **clearEvents** is necessary before the voltage can ramp up again. If the write value is **setEmergencyOff**, then all channels will have the state **EmergencyOff**, which means that the High Voltage will switch off without a ramp and reset of the **outputVoltage** to null volt.

If the write value is **disableKill**, then all channels will switch to **disableKill**.

If the write value is **enableKill**, then all channels will switch to **enableKill**.

If the write value is **clearEvents**, then all failure messages of the **outputStatus** will be reset (all channel events, all module events and the state **EmergencyOff**).

The status of **outputEnableKill** and **outputEmergencyOff** can be checked **with outputStatus or moduleStatus**. Both status calls provide details about channel and module operation and modes. Note, only active items are shown, i.e. if **enableKill** is not shown then the module is in **disableKill** mode

Item	Type	Access
outputStatus	bits	read

Status Information:

outputOn (0), output channel is on
outputInhibit(1), external (hardware-)inhibit of the output channel
outputFailureMinSenseVoltage (2), Sense voltage is too low
outputFailureMaxSenseVoltage (3), Sense voltage is too high
outputFailureMaxTerminalVoltage (4), Terminal voltage is too high
outputFailureMaxCurrent (5), Current is too high
outputFailureMaxTemperature (6), Heat sink temperature is too high
outputFailureMaxPower (7), Output power is too high
outputFailureTimeout (9), Communication timeout
outputCurrentLimited (10), Current limiting is active (constant current mode)
outputRampUp (11), Output voltage is increasing (e.g. after switch on)
outputRampDown (12), Output voltage is decreasing (e.g. after switch off)
outputEnableKill (13), EnableKill is active
outputEmergencyOff (14), EmergencyOff event is active
outputAdjusting (15), Fine adjustment is working
outputConstantVoltage (16), Voltage control (constant voltage mode)
outputLowCurrentRange (17), channel is in low current measurement range
outputCurrentBoundsExceeded (18), Output current is out of bounds
outputFailureCurrentLimit (19), Hardware current limit (EHS) / trip (EDS, EBS) was exceeded

ISEG high voltage modules have one common value for ramping up and down for all channels. This value can be set or read by using any channel number of the particular module as index.

For ISEG high voltage modules with 2 PCB's each of the sub-grups of one PCB may have one ramp value. In this case one should set the ramp twice by using a low and high channel number. ISEG EHQ, EHS, EDS and EBS modules typically have a ramp rate range from 1V/s 20% of Vnom (max. nominal voltage). In case enableKill is active the maximum ramp rate is reduced to 1% in order to lower the risk of unwanted trips during voltage ramp cycles.

Item	Type	Access	Unit	Range
outputVoltageRiseRate	float value	read-write	[V/s]	2V/s - 20% Vnom 1% (KILL enabled)

```
snmpset -Oqv -v 2c -M $path -m +WIENER-CRATE-MIB -c guru $ip
outputVoltageRiseRate.index F value
```

Item	Type	Access	Unit	Range
outputCurrentRiseRate	float value	read-write	[A/s]	2 - 100% nom. Val.
outputCurrentFallRate	float value	read-write	[A/s]	2 - 100% nom. Val.

DESCRIPTION

The **outputCurrentRiseRate** and **outputCurrentFallRate** accesses one data point of the HV modules and therefore will be reply always the same value.

ISEG EHS high voltage modules allow a sophisticated over current detection and handling. By default any current higher then the defined outputCurrent will cause the channel immediately to shut down / "KILL" the output voltage. This is the default mode "**enableKill**" but can also be activated by groupsSwitch.64 with value 5 or disabled by writing value 4.

Note the state enableKill or disableKill can be checked via outputStatus or moduleStatus.

Further ISEG EHS modules can be programmed into a delayed current trip mode. During the over current detection period the maximum output current is limited to the value defined by **outputCurrent**. The channel control is switching during this time from constant voltage to constant current mode. In case the over current is still present after the time out period different actions can be programmed for the channel / module as shown below.

Item	Type	Access	Unit	Range
outputTripTimeMaxCurrent	integer	read-write	[ms]	0, 16 – 4000 ms

DESCRIPTION

The **outputTripTimeMaxCurrent** defines a span for the time out function. The activity is depending from the programmed bit field **outputFailureMaxCurrent** of the item **outputSupervisionBehavior**. A write value of **0** is switching off the delayed trip function which was defined in the bit field **outputFailureMaxCurrent** of **outputSupervisionBehavior** before.

Item	Type	Access
outputSupervisionBehavior	integer	read-write

DESCRIPTION

A bit field packed into an integer which define the behaviour of the output channel / power supply after failures.

For each supervision value, a two-bit field exists. The enumeration of this value (..L+..H*2) is:

WIENER LV devices (MPV8xxx, MPV4xxx)

- 0 ignore the failure
- 1 switch off this channel

- 2 switch off all channels with the same group number
- 3 switch off the complete crate.

iseg HV devices

- 0 ignore the failure
- 1 switch off this channel by ramp down the voltage
- 2 switch off this channel by set a internal **EmergencyOff**
- 3 switch off the whole board of the HV module by set **EmergencyOff**.

The position of the bit fields in the integer value are:

- Bit 0, 1: outputFailureMinSenseVoltage
- Bit 2, 3: outputFailureMaxSenseVoltage
- Bit 4, 5: outputFailureMaxTerminalVoltage
- Bit 6, 7: **outputFailureMaxCurrent**
- Bit 8, 9: outputFailureMaxTemperature
- Bit 10, 11: outputFailureMaxPower
- Bit 12, 13: **outputFailureInhibit**
- Bit 14, 15: outputFailureTimeout

The ISEG EHS HV devices can use the bit fields:

outputFailureMaxCurrent support of the function delayed current trip
 The programmed activity will start when the actual current exceeded permanently the value of the item outputCurrent over the span of the programmed time out (set via the item outputTripTimeMaxCurrent).

outputFailureInhibit support of the optional hardware function EXTERNAL INHIBIT per channel
 The programmed activity will start when an external channel inhibit occurs

Note, the high voltage channel state has to be in **disableKill** for a proper work of the configuration of the behaviour for the functions above.

Settings for **outputSupervisionBehavior**:

Action	outputFailureMaxCurrent	outputFailureInhibit
Trigger	Over Current	External Signal (optional)
ignore the failure	0	0
switch off this channel by ramp down the voltage	64	4096
switch off this channel by set a internal EmergencyOff	128	8192
switch off the whole board of the HV module by set EmergencyOff	192	12288

supported firmware releases. In case of older firmware the software trip will not act, i.e. the error will be detected but no action (ramp-down/switch-off of channel) will happen. In case of older module firmware please contact support.

Name of firmware	Release or higher	Date	Description	Device class
E16D0	4.25	05/08/09	EDS 16/32 channel distributor module, with V_{max} from $V_{O_{max}}$ to $(V_{O_{max}} - 1kV)$	1
E16D1	4.25	05/08/09	EDS 16/32 distributor module	21
E08C0	2.22	02/23/09	EHS 4/8/16 channel, common GND module	24
E08F0	2.27	12/18/08	EHS 4/8/16 channel, floating GND module	25
E08F2	4.06	06/23/09	EHS 4/8/16 channel, floating GND module, 2 ranges for measurement of current	26
E08B0	1.02	07/10/09	EBS 8/16 bipolar channels, distributor module	28

Example of necessary SNMP commands for the programmed / delayed trip function:

/ allow programmed / delayed current trip by setting disableKill*/*

```
snmpset -Oqv -v 2c -m +WIENER-CRATE-MIB -c guru 192.168.2.25 groupsSwitch.64 i 4  
disableKill
```

```
snmpset -Oqv -v 2c -m +WIENER-CRATE-MIB -c guru 192.168.2.25 outputVoltage.u100 F  
60
```

60.000000 V

```
snmpset -Oqv -v 2c -m +WIENER-CRATE-MIB -c guru 192.168.2.25 outputSwitch.u100 i 1  
On
```

```
snmpget -Oqv -v 2c -m +WIENER-CRATE-MIB -c public 192.168.2.25 outputVoltage.u100  
60.000000 V
```

```
snmpget -Oqv -v 2c -m +WIENER-CRATE-MIB -c public 192.168.2.25  
outputMeasurementSenseVoltage.u100
```

60.104588 V

```
snmpget -Oqv -v 2c -m +WIENER-CRATE-MIB -c public 192.168.2.25  
outputMeasurementCurrent.u100
```

0.000001 A

```
snmpgetx -Oqv -v 2c -m +WIENER-CRATE-MIB -c public 192.168.2.25  
outputMeasurementCurrent.u100
```

0.000000735 A

```
snmpget -Oqv -v 2c -m +WIENER-CRATE-MIB -c public 192.168.2.25  
outputSupervisionBehavior.u100
```

0

```

snmpset -Oqv -v 2c -m +WIENER-CRATE-MIB -c guru 192.168.2.25
outputSupervisionBehavior.u100 i 64
64
snmpget -Oqv -v 2c -m +WIENER-CRATE-MIB -c public 192.168.2.25
outputSupervisionBehavior.u100
64
snmpget -Oqv -v 2c -m +WIENER-CRATE-MIB -c public 192.168.2.25
outputTripTimeMaxCurrent.u100
0 ms
snmpset -Oqv -v 2c -m +WIENER-CRATE-MIB -c guru 192.168.2.25
outputTripTimeMaxCurrent.u100 i 3000
3000 ms /* delay of 3 sconds */
snmpget -Oqv -v 2c -m +WIENER-CRATE-MIB -c public 192.168.2.25 outputStatus.u100
"80 " /* outputOn */
snmpgetx -Oqv -v 2c -m +WIENER-CRATE-MIB -c public 192.168.2.25
outputMeasurementCurrent.u100
0.000000735 A
snmpsetx -Oqv -v 2c -m +WIENER-CRATE-MIB -c guru 192.168.2.25 outputCurrent.u100
F 0.0000007
0.000000700 A
snmpget -Oqv -v 2c -m +WIENER-CRATE-MIB -c public 192.168.2.25 outputStatus.u100
"04 08 " /*outputFailureMaxCurrent, outputRampDown */
snmpget -Oqv -v 2c -m +WIENER-CRATE-MIB -c public 192.168.2.25 outputStatus.u100
"04 " /* outputFailureMaxCurrent */
snmpset -Oqv -v 2c -m +WIENER-CRATE-MIB -c guru 192.168.2.25 outputSwitch.u100 i
10
clearEvents
snmpsetx -Oqv -v 2c -m +WIENER-CRATE-MIB -c guru 192.168.2.25 outputCurrent.u100
F 0.00001
0.000010000 A
snmpset -Oqv -v 2c -m +WIENER-CRATE-MIB -c guru 192.168.2.25 outputSwitch.u100 i 1
On
snmpget -Oqv -v 2c -m +WIENER-CRATE-MIB -c public 192.168.2.25 outputStatus.u100
"80 10 " /* outputOn, outputRampUp */
/* a load has been switched on channel 0 to bring them in state CC current limited */
snmpget -Oqv -v 2c -m +WIENER-CRATE-MIB -c public 192.168.2.25 outputStatus.u100
"80 20 " /* outputOn, outputCurrentLimited */
.
snmpget -Oqv -v 2c -m +WIENER-CRATE-MIB -c public 192.168.2.25 outputStatus.u100

```



```
"80 20 " /* outputOn, outputCurrentLimited */
/* the delayed trip fuction ramps the voltage after 3 seconds to zero */
snmpget -Oqv -v 2c -m +WIENER-CRATE-MIB -c public 192.168.2.25 outputStatus.u100
"04 08 " /* outputFailureMaxCurrent, outputRampDown */
```

6.3.5 Special commands for WIENER low voltage modules

WIENER MPV low voltage modules can be operated in sensed or non-sensed mode and also allow different regulation characteristics to be programmed. Both the voltage at the sense as well as the terminal voltage are measured for each channel.

Also it is possible to set ramp up, and ramp-down rates for each channel individually as well as to define the switch-off characteristics accordingly.

MPV modules with index "I" are outfitted with channel-wise Inhibit signals.

Item	Type	Access
OutputUserConfig	bit field	read-write

DESCRIPTION

Usable for WIENER LV devices only. Community required for write access: guru. The position of the bit fields in the integer value are:

- Bit 0: Voltage ramping at switch off:
 - 0: Ramp down at switch off.
 - 1: No ramp at switch off (immediate off)
- Bit 1, 2: Set different regulation modes, dependent on the cable inductance:
 - 0: fast: short cables, up to 1 meter.
 - 1: moderate: cables from 1 to 30 meter.
 - 2: slow: cables longer than 30 meter.
 - 3: slow (identical to 2, should not be used)
- Bit 3: Internal sense line connection to the output (MPOD only):
 - 0: The sense input at the sense connector is used for regulation.
 - 1: The output voltage is used for regulation. Any signals at the sense connector are ignored.
- Bit 4: Enable External Inhibit input.
 - 0: The external inhibit input is ignored.
 - 1: The external inhibit input must be connected to a voltage source to allow switch on.
- Bit 5: Disable Global Inhibit inputs.
 - 0: The global inhibit/interlock inputs of the system is active.
 - 1: The global inhibit/interlock inputs of the system is ignored.
- Bit 6: Automatic Power On.
 - 0: After switching the main system switch ON, the output is not switched on automatically. A separate outputSwitch command is required.
 - 1: After switching the main system switch ON, the output is switched on automatically. If "Disable Global Inhibit" (bit 5) is set, the output will be switched on regardless of the global inhibit/interlock signals.

6.3.6 MPOD "module" parameters

Item	Type	Access
moduleNumber.0	INTEGER	read

Returns the number of plugged in modules

Item	Type	Access
moduleIndex	INTEGER	read

Returns the slot position of module with index ma0 to ma9

Item	Type	Access
moduleDescription	octet string	read

Returns module manufacturer name, firmware name, number of channels, serial number, firmware version, depends on module type.

for instance “iseg, E24D1, 24, 713100, 5.03”

“WIENER, MPV8016, 8, 6192”

moduleAuxiliaryMeasurementVoltage0	float	read
---	-------	------

ISEG ONLY: Returns the measurement value of the line supply 24 Volt.

moduleAuxiliaryMeasurementVoltage1	float	read
---	-------	------

ISEG ONLY: Returns the measurement value of the line supply 5 Volt.

ModuleAuxiliaryMeasurementTemperature0	float	read
---	-------	------

ModuleAuxiliaryMeasurementTemperature1	float	read
---	-------	------

ModuleAuxiliaryMeasurementTemperature2	float	read
---	-------	------

ModuleAuxiliaryMeasurementTemperature3	float	read
---	-------	------

ISEG ONLY: Returns the measured values of internal temperature probes (if installed)

moduleHardwareVoltageLimit	float	read
-----------------------------------	-------	------

ISEG ONLY: Returns the hardware voltage limit (front panel trimmer).

ModuleRampSpeedVoltage	float	read
-------------------------------	-------	------

ISEG ONLY: Returns the setting of the voltage ramp in % (same as for all channels).

ModuleRampSpeedCurrent	float	read
-------------------------------	-------	------

ISEG ONLY: Returns the setting of the current ramp in % (same as for all channels)

moduleStatus	bit string	read
---------------------	------------	------

ISEG: Returns the state of the module (bit returned with 1 is set),

moduleIsFineAdjustment (0), Module has reached state fine adjustment.

moduleIsLiveInsertion (2), Module is in state live insertion.

moduleNeedService (4), Hardware failure detected (consult iseg support).

moduleIsHardwareLimitVoltageGood (5), Hardware limit voltage in proper range, using for HV distributor modules with current mirror only.

moduleIsInputError (6), Input error in connection with a module access.

moduleIsNoSumError (8), All channels without any failure.
 moduleIsNoRamp (9), All channels stable, no is ramp active.
 moduleIsSafetyLoopGood (10), Safety loop is closed.
 moduleIsEventActive (11), Any event is active and mask is set.
 moduleIsGood (12), Module state is good.
 moduleIsSupplyGood (13), Power supply is good.
 moduleIsTemperatureGood (14), Module temperature is good.
 moduleIsKillEnable (15), Module state of kill enable.

6.3.7 MPOD Chassis, fan tray and power supply parameters

MPOD Controller / networking and interface settings:

Item	Type	Access
ipDynamicAddress	IP address	read
Returns the currently used IP address		

ipStaticAddress	IP address	read-write
------------------------	------------	------------

Returns the static IP address of the MPOD controller defined by the user. Writing a new static IP address will change the used address accordingly and may result in loss of communication until the new IP Address is used.

macAddress	Octet string	read-write
-------------------	--------------	------------

Returns / writes the MAC address of the MPOD controller.

MPOD fan settings:

Item	Type	Access
fanNominalSpeed	Integer	read-write

Returns the nominal fan rotation speed (RPM, Revolutions Per Minute). Writing value 0 does switch off the fans (only allowed if at least one rack temperature sensor is present). Values 1..1199 are not allowed, maximum speed is 3000.

MPOD power supply settings:

Item	Type	Access
psSerialNumber	Integer	read

Returns the serial number of the primary power supply.

psOperatingTime	Integer	read
------------------------	---------	------

Returns the run time in seconds of the primary power supply.

psAuxiliaryMeasurementVoltage	float	read
--------------------------------------	-------	------

Returns the measured primary output voltage in V for channels U0 to U7, typically channel U4 is used for 24V to power ISEG HV modules. In case of mixed MPOD/VME or MPOD/cPCI crates all other DC channels will be shown.

psAuxiliaryMeasurementCurrent	float	read
--------------------------------------	-------	------

Returns the measured current in A for channels U0 to U7.

6.3.8 ISEG HV Load Unit module commands

Item	Type	Access	Unit
outputMeasurementTerminalVoltage	float	read	[V]
outputMeasurementCurrent	float	read	[A]

DESCRIPTION

The items **outputMeasurementTerminalVoltage** and **outputMeasurementCurrent** return the voltage and current measured internally by the the load unit. These values are only measured if the external measurement and ripple measurement are turned off.

Item	Type	Access	Switch functions
outputSwitch	integer	read-write	clearEvents (10) setExternalAndRippleMeasurementOff (20) setExternalMeasurementOn (21) setRippleMeasurementOn (22) setExternalAndRippleMeasurementOn (23)

DESCRIPTION

The item **outputSwitch** allows to activate or deactivate external measurements for a channel via the measurement outputs on the front panel of the load unit.

The value **setExternalMeasurementOn** activates the voltage and current measurement outputs for the channel.

The value **setRippleMeasurementOn** activates the ripple measurement output for the channel.

The value **setExternalAndRippleMeasurementOn** activates all three measurement outputs for the channel.

The value **setExternalAndRippleMeasurementOn** deactivates all measurement outputs for the channel.

Note the measurement output can only be activated for one channel at the same time, i.e. if an output is activated for another channel the previously switched channel is deactivated.

If an external measurement output is activated no internal measurement will be executed. In order to reactivate the internal measurement, the external measurement must be completely deactivated. (If the current output status is unknown this can be done by writing **setExternalAndRippleMeasurementOn** and then **setExternalAndRippleMeasurementOff** for an arbitrary channel.)

All other SNMP items from the branch **outputTable** are readable for the SNMP compatibility but will not be used by the load unit.

6.4 Change of community names / setting of passwords

For the communication with MPOD modules 4 types of SNMP communities are used, "public", "private", "admin" and "guru". By default the community names are equal to the community types.

snmpwalk -v 2c -m +WIENER-CRATE-MIB -c guru 192.168.0.80

snmpCommunityName

```
WIENER-CRATE-MIB::snmpCommunityName.public = STRING: "public"  
WIENER-CRATE-MIB::snmpCommunityName.private = STRING: "private"  
WIENER-CRATE-MIB::snmpCommunityName.admin = STRING: "admin"  
WIENER-CRATE-MIB::snmpCommunityName.guru = STRING: "guru"
```

```
snmpwalk -v 2c -m +WIENER-CRATE-MIB -c private 192.168.0.80
```

snmpCommunityName

```
WIENER-CRATE-MIB::snmpCommunityName.public = STRING: "public"  
WIENER-CRATE-MIB::snmpCommunityName.private = STRING: "private"
```

In order to secure the MPOD system communication the community names can be used as passwords and be changed accordingly. The following example shows how the change and test the community names. Using a wrong community name will result in a time out error. Please note, that especially the communities with write access (private, admin, guru) should be protected.

```
snmpset -v 2c -m +WIENER-CRATE-MIB -c guru 192.168.0.80
```

snmpCommunityName.guru s seCrET

```
WIENER-CRATE-MIB::snmpCommunityName.guru = STRING: "seCrET"
```

```
snmpwalk -v 2c -m +WIENER-CRATE-MIB -c guru 192.168.0.80
```

snmpCommunityName

Timeout: No Response from 192.168.0.80

```
snmpwalk -v 2c -m +WIENER-CRATE-MIB -c seCrET 192.168.0.80
```

snmpCommunityName

```
WIENER-CRATE-MIB::snmpCommunityName.public = STRING: "public"  
WIENER-CRATE-MIB::snmpCommunityName.private = STRING: "private"  
WIENER-CRATE-MIB::snmpCommunityName.admin = STRING: "admin"  
WIENER-CRATE-MIB::snmpCommunityName.guru = STRING: "seCrET"
```

6.5 MIB Browser

There are several commercial or open source MIB-Browser programs available which can be used for SNMP communication. These provide often a simple GUI and allow SNMP calls. Following is a list of some free or open source MIB – browsers:

<http://www.ireasoning.com/mibbrowser.shtml>

http://www.serverscheck.com/mib_browser/

<http://www.mibble.org/>

<http://www.ks-soft.net/hostmon.eng/mibbrowser/index.htm>

<http://www.tembria.com/products/snmpbrowser/index.html>

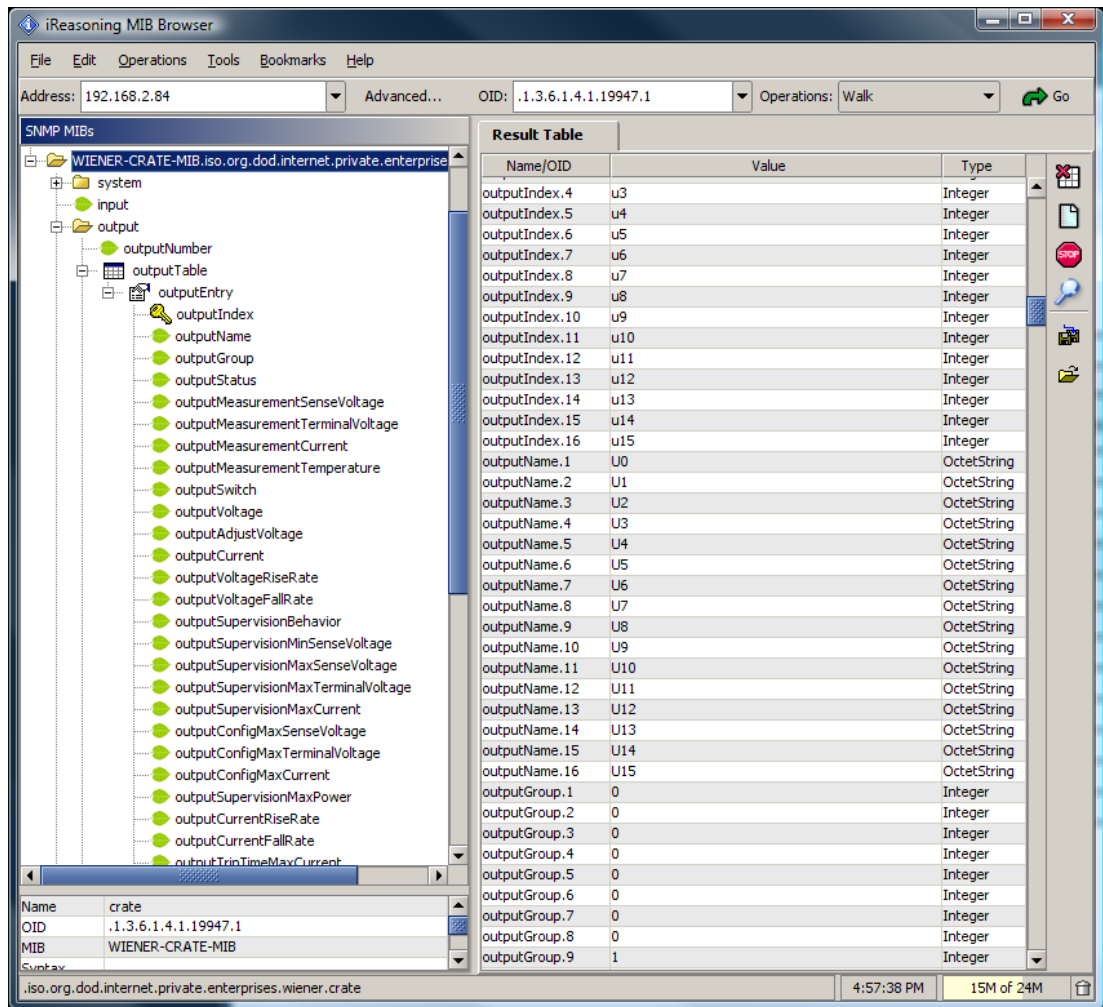

6.6 A BASH Simple Script for SNMP

All of the commands above could be combined into scripts to set and monitor a predefined set of channels. For example a Bash script to read all channels and set the voltages and current limit to the same value for each channel could look like:

```
#!/bin/bash
# Simple Bash Script that will read and set all channels in a MPOD crate

ip=192.168.2.25
path=/usr/share/snmp/mibs
setVoltage=5
setCurrent=.100
setStatus=1
setRamp=100

channelCount=$(snmpget -Oqv -v 2c -M $path -m +WIENER-CRATE-MIB -c guru $ip
outputNumber.0)
indices=$(snmpwalk -Oqv -v 2c -M $path -m +WIENER-CRATE-MIB -c guru $ip
outputIndex)
x=('echo $indices | tr ' ' ')

COUNTER=0
while [ $COUNTER -lt $channelCount ]; do
```

```

index=$(echo ${x[${COUNTER}]}))

voltage=$(snmpset -OqvU -v 2c -M $path -m +WIENER-CRATE-MIB -c guru $ip
outputVoltage.$index F $setVoltage)
iLimit=$(snmpset -OqvU -v 2c -M $path -m +WIENER-CRATE-MIB -c guru $ip
outputCurrent.$index F $setCurrent)
rampspeed=$(snmpset -OqvU -v 2c -M $path -m +WIENER-CRATE-MIB -c guru $ip
outputVoltageRiseRate.$index F $setRamp)
status=$(snmpset -OqvU -v 2c -M $path -m +WIENER-CRATE-MIB -c guru $ip
outputSwitch.$index i $setStatus)

voltage=$(snmpget -OqvU -v 2c -M $path -m +WIENER-CRATE-MIB -c guru $ip
outputVoltage.$index)
iLimit=$(snmpget -OqvU -v 2c -M $path -m +WIENER-CRATE-MIB -c guru $ip
outputCurrent.$index)
sense=$(snmpget -OqvU -v 2c -M $path -m +WIENER-CRATE-MIB -c guru $ip
outputMeasurementSenseVoltage.$index)
current=$(snmpget -OqvU -v 2c -M $path -m +WIENER-CRATE-MIB -c guru $ip
outputMeasurementCurrent.$index)
rampspeed=$(snmpget -OqvU -v 2c -M $path -m +WIENER-CRATE-MIB -c guru $ip
outputVoltageRiseRate.$index)
status=$(snmpget -OqvU -v 2c -M $path -m +WIENER-CRATE-MIB -c guru $ip
outputSwitch.$index)

echo "$voltage $iLimit $sense $current $rampspeed $status"

let COUNTER=COUNTER+1
done

```

6.7 MPOD SNMP Parameter List (most common)

Parameter	Multi	Access	Type
sysMainSwitch	1	R/W	i
sysStatus	1	R/W	i
sysVmeSysReset	1	R/W	i
outputNumber	1	R	i
groupsNumber	1	R	i
outputName	320	R	string
outputGroup	320	R	i
outputStatus	320	R	i
outputMeasurementSenseVoltage	320	R	F
outputMeasurementTerminalVoltage	320	R	F
outputMeasurementCurrent	320	R	F
outputMeasurementTemperature	320	R	i
outputSwitch	320	R/W	i
outputVoltage	320	R/W	F
outputCurrent	320	R/W	F
outputVoltageRiseRate	320	R/W	F
outputVoltageFallRate	320	R/W	F
outputSupervisionBehavior	320	R/W	i
outputSupervisionMinSenseVoltage	320	R/W	F
outputSupervisionMaxSenseVoltage	320	R/W	F
outputSupervisionMaxTerminalVoltage	320	R/W	F
outputSupervisionMaxCurrent	320	R/W	F
outputSupervisionMaxTemperature	320	R/W	i
outputConfigMaxSenseVoltage	320	R	F
outputConfigMaxTerminalVoltage	320	R	F
outputConfigMaxCurrent	320	R	F
outputConfigMaxPower	320	R	F
sensorNumber	1	R	i
sensorTemperature	12	R	i
sensorWarningThreshold	12	R/W	i
sensorFailureThreshold	12	R/W	i
snmpCommunityName	4	R/W	string
psFirmwareVersion	1	R	string
psSerialNumber	1	R	string
psOperatingTime	1	R	i
psDirectAccess	1	R/W	string
fanFirmwareVersion	1	R	string
fanSerialNumber	1	R	string
fanOperatingTime	1	R	i
fanAirTemperature	1	R	i
fanSwicthOffDelay	1	R/W	i
fanNominalSpeed	1	R/W	i
fanNumberOfFans	1	R	i
fanSpeed	6	R	i

(see SNMP tree structure at end of manual for full structure)

6.8 LabView Control Program (NETSNMP)

All LabView MPOD function VI's are using SNMP calls from the WIENER_SNMP_LV.DLL. This DLL requires the installation of NETSNMP and the WIENER -CRATE-MIB.txt file as described in Chapter 6.3!

The supplied LabView programs allow controlling both low and high voltage channels for small configurations of up to 10 MPOD modules. The program is provided as executable which will require the NI LV Run-time-engine. All source code is available on the CD-ROM. Please run these VI's with either LabView 8.6 LV2010 or higher .

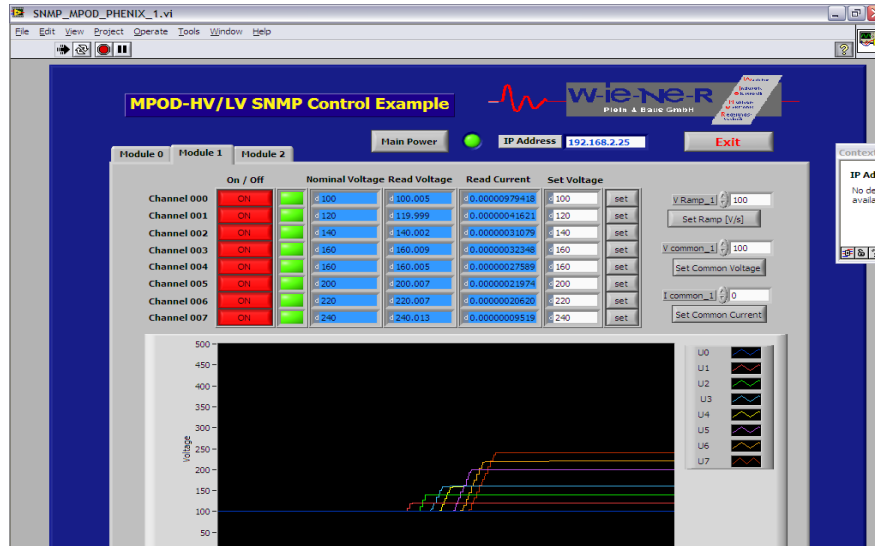

Example for LabView VI for 8 channel high voltage module

6.9 ISEG SNMP Control Program (NETSNMP)

The supplied iseg SNMP Control program allow controlling high voltage channels for configurations of up to 10 HV or LV modules plugged into the MPOD crate. The programs are provided as executable. All source code is available on the CD-ROM.

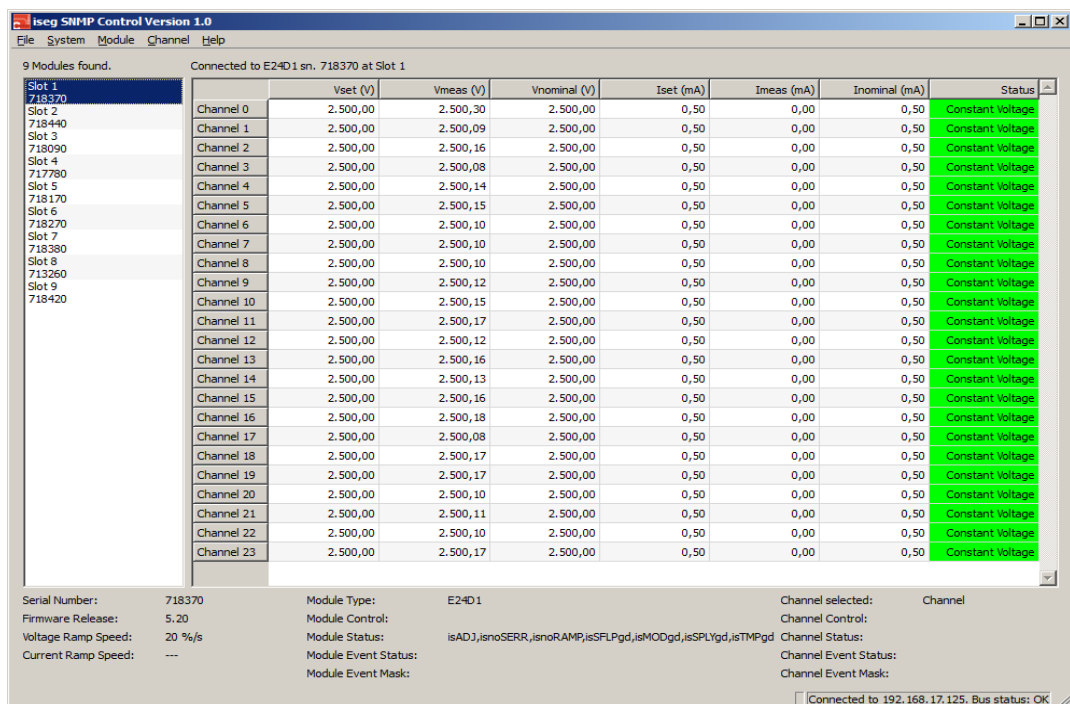

6.10 C++ programming (NetSNMP)

Using NetSNMP C++ programs can be easily written for monitoring and control of MPOD low / high voltage modules. For Windows all needed functions are provided by a dynamically loadable library WIENER_SNMP.DLL. This DLL requires NETSNMP and the WIENER – CRATE-MIB.txt file as described in chapter 6.3!

The following functions are provided in this library (for details see source code):

Snmplib
SnmplibCleanup
SnmplibOpen
SnmplibClose

getMainSwitch
setMainSwitch
getMainStatus
getVmeReset
setVmeReset

getOutputNumber
getOutputGroups
getOutputGroup
getChannelStatus
getOutputSenseMeasurement
getOutputTerminalMeasurement
getCurrentMeasurement
getTemperatureMeasurement
setChannelSwitch
getChannelSwitch
getOutputVoltage
setOutputVoltage
getOutputCurrent
setOutputCurrent
getOutputRiseRate
setOutputRiseRate
getOutputFallRate
setOutputFallRate
getOutputSupervisionBehavior
setOutputSupervisionBehavior
getOutputSupervisionMinSenseVoltage
setOutputSupervisionMinSenseVoltage
getOutputSupervisionMaxSenseVoltage
setOutputSupervisionMaxSenseVoltage
getOutputSupervisionMaxTerminalVoltage
setOutputSupervisionMaxTerminalVoltage
getOutputSupervisionMaxCurrent
setOutputSupervisionMaxCurrent
getOutputSupervisionMaxTemperature
getOutputConfigMaxSenseVoltage
getOutputConfigMaxTerminalVoltage
getOutputConfigMaxCurrent
getOutputConfigMaxPower

getSensorNumber

getSensorTemp
getSensorWarningTemperature
setSensorWarningTemperature
getSensorFailureTemperature
setSensorFailureTemperature

getPsOperatingTime

getFanOperatingTime
getFanAirTemperature
getFanSwitchOffDelay
setFanSwitchOffDelay
getFanNominalSpeed
setFanNominalSpeed
setFanNominalSpeed
getFanNumberOfFans
getFanSpeed

snmpSetDouble
snmpGetDouble
snmpSetInt
snmpGetInt

7 MPOD Crate

Powered chassis for multichannel low and high voltage modules

Construction	8 or 9U x 19" crate	max.10 modules, up to3 kW output power / 3,6kW input power
	Slots:	10 + ½ (MPOD controller)
	Dimensions (w, h, d)	483 mm x 460 mm x 355 mm
	Weight:	31,5 kg

8 Primary Power Supply

The power supply provides all necessary supply voltages for the LV- and HV-Modules.
It is connected to the mains (World wide input 100..240V AC, 50..60 Hz).

- World wide input: 100..240V AC, 50..60 Hz, single phase
- Sinusoidal current input, up to 16A, depending on the used modules

8.1 Power Box Data Sheet

3U box with max. 6 power modules.

Mains Input

Rated Input Voltage:		106 – 230 V AC, +/- 15% variation allowed
Rated Input Current:		16 A
Sinusoidal:	CE	CE EN 60555, IEC 555 pow. fact. 0,98 (230VAC)
Inrush current:		16 A, cold unit
Input protection:		An external fuse or circuit breaker has to be installed (16A max.)
RF rejection:		EN 55 022 Class B, Input and Output
Output protection overload:		current limiting for booster circuits, 90°C cut off temperature
Dimensions:		4U x 14 PU width acc. to IEC 60297, 450 mm deep
Weight:		4,7 kg
Operation temperature:		0...45°C without derating, storage: -30°C ... + 85°C
MTBF	electronics:	40°C ambient: ca. 100 000 h
	integrated fan:	40°C ambient: ca. 65 000 h, 25° ambient >85000h

9 MPOD Low Voltage module MPV 8xx data sheet

- 8 channel low voltage module with floating outputs with individual return lines and sense lines
- Polarity configurable, outputs are insulated from each other and the chassis mainframe earth with 125V DC working voltage (Test voltage = 500VDC)
- 0.2% / 10K output voltage stability
- Voltage set / monitor: 15 bit resolution, +/-0.1% of full scale or better accuracy, measurement of both sense and terminal voltage
- Current limit set / monitor: 15 bit resolution, +/-0.5% of full scale or better accuracy
- Ramp-up / down programmable from 1 V/s to 500 V/s in 1 V/s steps.
- Output Voltage Ripple:
 - < 10mV_{pp}; 1mV_{Rms} with 350MHz Bandwidth
 - < 5mV_{pp}; 0.5mV_{Rms} with 100MHz Bandwidth
 - < 3mV_{pp}; 0.5mV_{Rms} with 20MHz Bandwidth
- Low conducted disturbance current (Funkstörstrom TÜV)
- Static Regulation: < 10mV
- Dynamic Regulation: <100mV with I = +/- 25% change and 70A/s
recovery time < 5mS
- Dimensions: 6U x 40.64mm x 220mm
- Front Panel Indicators: tri-color LED's with on / off / failure for every channel
- Output Channels Connectors:
 - a) 2x 37-pin D-sub (outputs, returns, sense lines, chassis and interlock loop pair)
 - b) 2 x 8 pin high current sub-D and 37-pin sense/control connector
- Interlock Loop – optional
- Safety Loop – in connector PIN 18 and 37

Type	Channels	Voltage	I Max	Peak Power	V-Res	I-Res	Ripple
MPV 8008D	8	0 to 8V	10A	50W / ch.	0.5mV	0.5mA	<3mVpp
MPV 8008I	8	0 to 8V	10A	50W / ch.	0.5mV	0.5mA	<3mVpp
MPV 8008LD	8	0 to 8V	5A	40W / ch.	0.5mV	0.25mA	<3mVpp
MPV 8008LI	8	0 to 8V	5A	40W / ch.	0.5mV	0.25mA	<3mVpp
MPV 8016D	8	0 to 15V	5A	50W / ch.	1mV	0.25mA	<2mVpp
MPV 8016I	8	0 to 15V	5A	50W / ch.	1mV	0.25mA	<2mVpp
MPV 8030D	8	0 to 30V	2.5A	50W / ch.	2mV	0.12mA	<2mVpp
MPV 8030I	8	0 to 30V	2.5A	50W / ch.	2mV	0.12mA	<2mVpp
MPV 8060D	8	0 to 60V	1A	50W / ch.	4mV	0.06mA	<2mVpp
MPV 8060I	8	0 to 60V	1A	50W / ch.	4mV	0.06mA	<2mVpp
MPV 8120D	8	0 to 120V	100mA	50W / ch.	4mV	4 µA	<2mVpp
MPV 8120I	8	0 to 120V	100mA	50W / ch.	4mV	4 µA	<2mVpp

Regulation fast remote sense circuit (short sensed distance, sense connected to output at the MPOD module):

Static:	MVP 2-8 V	< 15 mV	(+/-100% load, +/- full mains range)
	MVP other voltages	< 0.05 %	(+/-100% load, +/- full DC input range)
Dynamic (0.5 m wire):	MVP 2-8 V	< 100 mV	(50 % - 75 % load change)
	other	< 0.7 %	(50 % - 75 % load change)
Recovery Time:	MVP 2-8V	1%: 0.2 ms 0.1%: 0.5 ms	(50 % - 75 % load change)
	MVP 5-16V, 7-24V	1%: 0.0 ms 0.1%: 1.0 ms	(50 % - 75 % load change)
	MVP 30-60V	1%: 0.5 ms 0.1%: 1.0 ms	(50 % - 75 % load change)
Conditions	Current slope <1000A/ms, 200uF per 1A parallel to load, fast regulation mode selected.		

Regulation slow remote sense circuit (long sensed distance):

Static:	MVP 2-8V/ 30-60V	< 15 mV	(+/-100% load, +/- full mains range)
	Other	< 0.05 %	(+/-100% load, +/- full mains range)
Dynamic:	Dynamic deviation depends on current slope resp. filter capacitors at load side only 30m cable to load, 0,3mF capacitance at load side, 1V drop at nominal load, 10% - 90 % load change with 3ms slope (50A output= 13,33A/ms) leads to less than 10% temporary output voltage deviation		
Recovery Time (40m wire, 5V at load side, $U_{drop} < 2 V$):	MVP 2-7V, 2-8V	10%: <15 ms 1%: <25 ms	(50 % - 75 % load change)
	Other	10%: <15 ms 1%: < 33 ms	(50 % - 75 % load change)

```
snmpget -Oqv -v 2c -m +WIENER-CRATE-MIB -c public 192.168.16.222 outputVoltage.u100  
60.000000 V
```

```
snmpget -Oqv -v 2c -m +WIENER-CRATE-MIB -c public 192.168.16.222 outputMeasurementSenseVoltage.u100  
60.104588 V
```

```
snmpget -Oqv -v 2c -m +WIENER-CRATE-MIB -c public 192.168.16.222 outputMeasurementSenseVoltage.u100  
60.104713 V
```

```
snmpget -Oqv -v 2c -m +WIENER-CRATE-MIB -c public 192.168.16.222 outputMeasurementCurrent.u100  
0.000001 A
```

```
snmpgetx -Oqv -v 2c -m +WIENER-CRATE-MIB -c public 192.168.16.222 outputMeasurementCurrent.u100  
0.000000735 A
```

```
snmpget -Oqv -v 2c -m +WIENER-CRATE-MIB -c public 192.168.16.222 outputSupervisionBehavior.u100  
0
```

```
snmpset -Oqv -v 2c -m +WIENER-CRATE-MIB -c guru 192.168.16.222 outputSupervisionBehavior.u100 i 64  
64
```

```
snmpget -Oqv -v 2c -m +WIENER-CRATE-MIB -c public 192.168.16.222 outputSupervisionBehavior.u100  
64
```

```
snmpget -Oqv -v 2c -m +WIENER-CRATE-MIB -c public 192.168.16.222 outputTripTimeMaxCurrent.u100  
0 ms
```

```
snmpset -Oqv -v 2c -m +WIENER-CRATE-MIB -c guru 192.168.16.222 outputTripTimeMaxCurrent.u100 i 3000  
3000 ms /* delay of 3 sconds */
```

```
snmpget -Oqv -v 2c -m +WIENER-CRATE-MIB -c public 192.168.16.222 outputStatus.u100  
"80 " /* outputOn */
```

```
snmpgetx -Oqv -v 2c -m +WIENER-CRATE-MIB -c public 192.168.16.222 outputMeasurementCurrent.u100  
0.000000735 A
```

```
snmpsetx -Oqv -v 2c -m +WIENER-CRATE-MIB -c guru 192.168.16.222 outputCurrent.u100 F 0.0000007  
0.000000700 A
```

```
snmpget -Oqv -v 2c -m +WIENER-CRATE-MIB -c public 192.168.16.222 outputStatus.u100  
"04 08 " /*outputFailureMaxCurrent, outputRampDown */
```



```

snmpget -Oqv -v 2c -m +WIENER-CRATE-MIB -c public 192.168.16.222 outputStatus.u100
"04 " /* outputFailureMaxCurrent */

snmpset -Oqv -v 2c -m +WIENER-CRATE-MIB -c guru 192.168.16.222 outputSwitch.u100 i 10
clearEvents

snmpsetx -Oqv -v 2c -m +WIENER-CRATE-MIB -c guru 192.168.16.222 outputCurrent.u100 F 0.00001
0.000010000 A

snmpset -Oqv -v 2c -m +WIENER-CRATE-MIB -c guru 192.168.16.222 outputSwitch.u100 i 1
On

snmpget -Oqv -v 2c -m +WIENER-CRATE-MIB -c public 192.168.16.222 outputStatus.u100
"80 10 " /* outputOn, outputRampUp */

/* a load has been switched on channel 0 to bring them in state CC current limited */
snmpget -Oqv -v 2c -m +WIENER-CRATE-MIB -c public 192.168.16.222 outputStatus.u100
"80 20 " /* outputOn, outputCurrentLimited */

snmpget -Oqv -v 2c -m +WIENER-CRATE-MIB -c public 192.168.16.222 outputStatus.u100
"80 20 " /* outputOn, outputCurrentLimited */

snmpget -Oqv -v 2c -m +WIENER-CRATE-MIB -c public 192.168.16.222 outputStatus.u100
"80 20 " /* outputOn, outputCurrentLimited */

snmpget -Oqv -v 2c -m +WIENER-CRATE-MIB -c public 192.168.16.222 outputStatus.u100
"80 20 " /* outputOn, outputCurrentLimited */

snmpget -Oqv -v 2c -m +WIENER-CRATE-MIB -c public 192.168.16.222 outputStatus.u100
"80 20 " /* outputOn, outputCurrentLimited */

/* the delayed trip fuction pamps the voltage after 3 seconds to zero */
snmpget -Oqv -v 2c -m +WIENER-CRATE-MIB -c public 192.168.16.222 outputStatus.u100
"04 08 " /* outputFailureMaxCurrent, outputRampDown */

snmpget -Oqv -v 2c -m +WIENER-CRATE-MIB -c public 192.168.16.222 outputStatus.u100
"04 08 " /* outputFailureMaxCurrent, outputRampDown */

```

11 WIENER SNMP Parameter structure

```
// GENERATED WITH
// snmptranslate -w 120 -Tp WIENER-CRATE-MIB::crate > SnmpTree.txt
//

+--crate(1)
  +--system(1)
    | +-- -RW- EnumVal sysMainSwitch(1)
    | |   Values: off(0), on(1)
    | +-- -R- BitString sysStatus(2)
    | |   Values: mainOn(0), mainInhibit(1), localControlOnly(2), inputFailure(3), outputFailure(4),
    | |   fantrayFailure(5), sensorFailure(6), vmeSysfail(7), plugAndPlayIncompatible(8)
    | +-- -RW- EnumVal sysVmeSysReset(3)
    | |   Values: trigger(1)
    | +-- -RW- INTEGER sysHardwareReset(4)
    | +-- -RW- BitString sysConfigDoMeasurementCurrent(10)
    | |   Values: ch0(0), ch1(1), ch2(2), ch3(3), ch4(4), ch5(5), ch6(6), ch7(7)
    | +-- -RW- Integer32 sysOperatingTime(11)
    | +-- -RW- String sysMemoryAccess(127)
    | |   Size: 516
    | +-- -RW- Integer32 sysDebugMemory8(1024)
    | |   Range: 0..255
    | +-- -RW- Integer32 sysDebugMemory16(1025)
    | |   Range: 0..65535
    | +-- -RW- Integer32 sysDebugMemory32(1026)
    | |   Range: -2147483648..2147483647
    |
  +--input(2)
  +--output(3)
    | +-- -R- Integer32 outputNumber(1)
    | |   Range: 0..1999
    |
    +--outputTable(2)
      |
      +--outputEntry(1)
        | Index: outputIndex
        |
        +-- ---- EnumVal outputIndex(1)
          | Values: u0(1), u1(2), u2(3), u3(4), u4(5), u5(6), u6(7), u7(8), u8(9), u9(10), u10(11), u11(12),
          | u12(13), u13(14), u14(15), u15(16), u16(17), u17(18), u18(19), u19(20), u20(21), u21(22),
          | u22(23), u23(24), u24(25), u25(26), u26(27), u27(28), u28(29), u29(30), u30(31), u31(32),
          | u32(33), u33(34), u34(35), u35(36), u36(37), u37(38), u38(39), u39(40), u40(41), u41(42),
          | u42(43), u43(44), u44(45), u45(46), u46(47), u47(48), u48(49), u49(50), u50(51), u51(52),
          | u52(53), u53(54), u54(55), u55(56), u56(57), u57(58), u58(59), u59(60), u60(61), u61(62),
          | u62(63), u63(64), u64(65), u65(66), u66(67), u67(68), u68(69), u69(70), u70(71), u71(72),
          | u72(73), u73(74), u74(75), u75(76), u76(77), u77(78), u78(79), u79(80), u80(81), u81(82),
          | u82(83), u83(84), u84(85), u85(86), u86(87), u87(88), u88(89), u89(90), u90(91), u91(92),
          | u92(93), u93(94), u94(95), u95(96), u96(97), u97(98), u98(99), u99(100), u100(101),
          | u101(102), u102(103), u103(104), u104(105), u105(106), u106(107), u107(108), u108(109),
          | u109(110), u110(111), u111(112), u112(113), u113(114), u114(115), u115(116), u116(117),
          | u117(118), u118(119), u119(120), u120(121), u121(122), u122(123), u123(124), u124(125),
          | u125(126), u126(127), u127(128), u128(129), u129(130), u130(131), u131(132), u132(133),
          | u133(134), u134(135), u135(136), u136(137), u137(138), u138(139), u139(140), u140(141),
          | u141(142), u142(143), u143(144), u144(145), u145(146), u146(147), u147(148), u148(149),
          | u149(150), u150(151), u151(152), u152(153), u153(154), u154(155), u155(156), u156(157),
          | u157(158), u158(159), u159(160), u160(161), u161(162), u162(163), u163(164), u164(165),
          | u165(166), u166(167), u167(168), u168(169), u169(170), u170(171), u171(172), u172(173),
          | u173(174), u174(175), u175(176), u176(177), u177(178), u178(179), u179(180), u180(181),
          | u181(182), u182(183), u183(184), u184(185), u185(186), u186(187), u187(188), u188(189),
          | u189(190), u190(191), u191(192), u192(193), u193(194), u194(195), u195(196), u196(197),
          | u197(198), u198(199), u199(200), u200(201), u201(202), u202(203), u203(204), u204(205),
          | u205(206), u206(207), u207(208), u208(209), u209(210), u210(211), u211(212), u212(213),
```

u213(214), u214(215), u215(216), u216(217), u217(218), u218(219), u219(220), u220(221),
u221(222), u222(223), u223(224), u224(225), u225(226), u226(227), u227(228), u228(229),
u229(230), u230(231), u231(232), u232(233), u233(234), u234(235), u235(236), u236(237),
u237(238), u238(239), u239(240), u240(241), u241(242), u242(243), u243(244), u244(245),
u245(246), u246(247), u247(248), u248(249), u249(250), u250(251), u251(252), u252(253),
u253(254), u254(255), u255(256), u256(257), u257(258), u258(259), u259(260), u260(261),
u261(262), u262(263), u263(264), u264(265), u265(266), u266(267), u267(268), u268(269),
u269(270), u270(271), u271(272), u272(273), u273(274), u274(275), u275(276), u276(277),
u277(278), u278(279), u279(280), u280(281), u281(282), u282(283), u283(284), u284(285),
u285(286), u286(287), u287(288), u288(289), u289(290), u290(291), u291(292), u292(293),
u293(294), u294(295), u295(296), u296(297), u297(298), u298(299), u299(300), u300(301),
u301(302), u302(303), u303(304), u304(305), u305(306), u306(307), u307(308), u308(309),
u309(310), u310(311), u311(312), u312(313), u313(314), u314(315), u315(316), u316(317),
u317(318), u318(319), u319(320), u320(321), u321(322), u322(323), u323(324), u324(325),
u325(326), u326(327), u327(328), u328(329), u329(330), u330(331), u331(332), u332(333),
u333(334), u334(335), u335(336), u336(337), u337(338), u338(339), u339(340), u340(341),
u341(342), u342(343), u343(344), u344(345), u345(346), u346(347), u347(348), u348(349),
u349(350), u350(351), u351(352), u352(353), u353(354), u354(355), u355(356), u356(357),
u357(358), u358(359), u359(360), u360(361), u361(362), u362(363), u363(364), u364(365),
u365(366), u366(367), u367(368), u368(369), u369(370), u370(371), u371(372), u372(373),
u373(374), u374(375), u375(376), u376(377), u377(378), u378(379), u379(380), u380(381),
u381(382), u382(383), u383(384), u384(385), u385(386), u386(387), u387(388), u388(389),
u389(390), u390(391), u391(392), u392(393), u393(394), u394(395), u395(396), u396(397),
u397(398), u398(399), u399(400), u400(401), u401(402), u402(403), u403(404), u404(405),
u405(406), u406(407), u407(408), u408(409), u409(410), u410(411), u411(412), u412(413),
u413(414), u414(415), u415(416), u416(417), u417(418), u418(419), u419(420), u420(421),
u421(422), u422(423), u423(424), u424(425), u425(426), u426(427), u427(428), u428(429),
u429(430), u430(431), u431(432), u432(433), u433(434), u434(435), u435(436), u436(437),
u437(438), u438(439), u439(440), u440(441), u441(442), u442(443), u443(444), u444(445),
u445(446), u446(447), u447(448), u448(449), u449(450), u450(451), u451(452), u452(453),
u453(454), u454(455), u455(456), u456(457), u457(458), u458(459), u459(460), u460(461),
u461(462), u462(463), u463(464), u464(465), u465(466), u466(467), u467(468), u468(469),
u469(470), u470(471), u471(472), u472(473), u473(474), u474(475), u475(476), u476(477),
u477(478), u478(479), u479(480), u480(481), u481(482), u482(483), u483(484), u484(485),
u485(486), u486(487), u487(488), u488(489), u489(490), u490(491), u491(492), u492(493),
u493(494), u494(495), u495(496), u496(497), u497(498), u498(499), u499(500), u500(501),
u501(502), u502(503), u503(504), u504(505), u505(506), u506(507), u507(508), u508(509),
u509(510), u510(511), u511(512), u512(513), u513(514), u514(515), u515(516), u516(517),
u517(518), u518(519), u519(520), u520(521), u521(522), u522(523), u523(524), u524(525),
u525(526), u526(527), u527(528), u528(529), u529(530), u530(531), u531(532), u532(533),
u533(534), u534(535), u535(536), u536(537), u537(538), u538(539), u539(540), u540(541),
u541(542), u542(543), u543(544), u544(545), u545(546), u546(547), u547(548), u548(549),
u549(550), u550(551), u551(552), u552(553), u553(554), u554(555), u555(556), u556(557),
u557(558), u558(559), u559(560), u560(561), u561(562), u562(563), u563(564), u564(565),
u565(566), u566(567), u567(568), u568(569), u569(570), u570(571), u571(572), u572(573),
u573(574), u574(575), u575(576), u576(577), u577(578), u578(579), u579(580), u580(581),
u581(582), u582(583), u583(584), u584(585), u585(586), u586(587), u587(588), u588(589),
u589(590), u590(591), u591(592), u592(593), u593(594), u594(595), u595(596), u596(597),
u597(598), u598(599), u599(600), u600(601), u601(602), u602(603), u603(604), u604(605),
u605(606), u606(607), u607(608), u608(609), u609(610), u610(611), u611(612), u612(613),
u613(614), u614(615), u615(616), u616(617), u617(618), u618(619), u619(620), u620(621),
u621(622), u622(623), u623(624), u624(625), u625(626), u626(627), u627(628), u628(629),
u629(630), u630(631), u631(632), u632(633), u633(634), u634(635), u635(636), u636(637),
u637(638), u638(639), u639(640), u640(641), u641(642), u642(643), u643(644), u644(645),
u645(646), u646(647), u647(648), u648(649), u649(650), u650(651), u651(652), u652(653),
u653(654), u654(655), u655(656), u656(657), u657(658), u658(659), u659(660), u660(661),
u661(662), u662(663), u663(664), u664(665), u665(666), u666(667), u667(668), u668(669),
u669(670), u670(671), u671(672), u672(673), u673(674), u674(675), u675(676), u676(677),
u677(678), u678(679), u679(680), u680(681), u681(682), u682(683), u683(684), u684(685),
u685(686), u686(687), u687(688), u688(689), u689(690), u690(691), u691(692), u692(693),
u693(694), u694(695), u695(696), u696(697), u697(698), u698(699), u699(700), u700(701),
u701(702), u702(703), u703(704), u704(705), u705(706), u706(707), u707(708), u708(709),
u709(710), u710(711), u711(712), u712(713), u713(714), u714(715), u715(716), u716(717),
u717(718), u718(719), u719(720), u720(721), u721(722), u722(723), u723(724), u724(725),

u725(726), u726(727), u727(728), u728(729), u729(730), u730(731), u731(732), u732(733),
u733(734), u734(735), u735(736), u736(737), u737(738), u738(739), u739(740), u740(741),
u741(742), u742(743), u743(744), u744(745), u745(746), u746(747), u747(748), u748(749),
u749(750), u750(751), u751(752), u752(753), u753(754), u754(755), u755(756), u756(757),
u757(758), u758(759), u759(760), u760(761), u761(762), u762(763), u763(764), u764(765),
u765(766), u766(767), u767(768), u768(769), u769(770), u770(771), u771(772), u772(773),
u773(774), u774(775), u775(776), u776(777), u777(778), u778(779), u779(780), u780(781),
u781(782), u782(783), u783(784), u784(785), u785(786), u786(787), u787(788), u788(789),
u789(790), u790(791), u791(792), u792(793), u793(794), u794(795), u795(796), u796(797),
u797(798), u798(799), u799(800), u800(801), u801(802), u802(803), u803(804), u804(805),
u805(806), u806(807), u807(808), u808(809), u809(810), u810(811), u811(812), u812(813),
u813(814), u814(815), u815(816), u816(817), u817(818), u818(819), u819(820), u820(821),
u821(822), u822(823), u823(824), u824(825), u825(826), u826(827), u827(828), u828(829),
u829(830), u830(831), u831(832), u832(833), u833(834), u834(835), u835(836), u836(837),
u837(838), u838(839), u839(840), u840(841), u841(842), u842(843), u843(844), u844(845),
u845(846), u846(847), u847(848), u848(849), u849(850), u850(851), u851(852), u852(853),
u853(854), u854(855), u855(856), u856(857), u857(858), u858(859), u859(860), u860(861),
u861(862), u862(863), u863(864), u864(865), u865(866), u866(867), u867(868), u868(869),
u869(870), u870(871), u871(872), u872(873), u873(874), u874(875), u875(876), u876(877),
u877(878), u878(879), u879(880), u880(881), u881(882), u882(883), u883(884), u884(885),
u885(886), u886(887), u887(888), u888(889), u889(890), u890(891), u891(892), u892(893),
u893(894), u894(895), u895(896), u896(897), u897(898), u898(899), u899(900), u900(901),
u901(902), u902(903), u903(904), u904(905), u905(906), u906(907), u907(908), u908(909),
u909(910), u910(911), u911(912), u912(913), u913(914), u914(915), u915(916), u916(917),
u917(918), u918(919), u919(920), u920(921), u921(922), u922(923), u923(924), u924(925),
u925(926), u926(927), u927(928), u928(929), u929(930), u930(931), u931(932), u932(933),
u933(934), u934(935), u935(936), u936(937), u937(938), u938(939), u939(940), u940(941),
u941(942), u942(943), u943(944), u944(945), u945(946), u946(947), u947(948), u948(949),
u949(950), u950(951), u951(952), u952(953), u953(954), u954(955), u955(956), u956(957),
u957(958), u958(959), u959(960), u960(961), u961(962), u962(963), u963(964), u964(965),
u965(966), u966(967), u967(968), u968(969), u969(970), u970(971), u971(972), u972(973),
u973(974), u974(975), u975(976), u976(977), u977(978), u978(979), u979(980), u980(981),
u981(982), u982(983), u983(984), u984(985), u985(986), u986(987), u987(988), u988(989),
u989(990), u990(991), u991(992), u992(993), u993(994), u994(995), u995(996), u996(997),
u997(998), u998(999), u999(1000), u1000(1001), u1001(1002), u1002(1003), u1003(1004),
u1004(1005), u1005(1006), u1006(1007), u1007(1008), u1008(1009), u1009(1010),
u1010(1011), u1011(1012), u1012(1013), u1013(1014), u1014(1015), u1015(1016),
u1016(1017), u1017(1018), u1018(1019), u1019(1020), u1020(1021), u1021(1022),
u1022(1023), u1023(1024), u1024(1025), u1025(1026), u1026(1027), u1027(1028),
u1028(1029), u1029(1030), u1030(1031), u1031(1032), u1032(1033), u1033(1034),
u1034(1035), u1035(1036), u1036(1037), u1037(1038), u1038(1039), u1039(1040),
u1040(1041), u1041(1042), u1042(1043), u1043(1044), u1044(1045), u1045(1046),
u1046(1047), u1047(1048), u1048(1049), u1049(1050), u1050(1051), u1051(1052),
u1052(1053), u1053(1054), u1054(1055), u1055(1056), u1056(1057), u1057(1058),
u1058(1059), u1059(1060), u1060(1061), u1061(1062), u1062(1063), u1063(1064),
u1064(1065), u1065(1066), u1066(1067), u1067(1068), u1068(1069), u1069(1070),
u1070(1071), u1071(1072), u1072(1073), u1073(1074), u1074(1075), u1075(1076),
u1076(1077), u1077(1078), u1078(1079), u1079(1080), u1080(1081), u1081(1082),
u1082(1083), u1083(1084), u1084(1085), u1085(1086), u1086(1087), u1087(1088),
u1088(1089), u1089(1090), u1090(1091), u1091(1092), u1092(1093), u1093(1094),
u1094(1095), u1095(1096), u1096(1097), u1097(1098), u1098(1099), u1099(1100),
u1100(1101), u1101(1102), u1102(1103), u1103(1104), u1104(1105), u1105(1106),
u1106(1107), u1107(1108), u1108(1109), u1109(1110), u1110(1111), u1111(1112),
u1112(1113), u1113(1114), u1114(1115), u1115(1116), u1116(1117), u1117(1118),
u1118(1119), u1119(1120), u1120(1121), u1121(1122), u1122(1123), u1123(1124),
u1124(1125), u1125(1126), u1126(1127), u1127(1128), u1128(1129), u1129(1130),
u1130(1131), u1131(1132), u1132(1133), u1133(1134), u1134(1135), u1135(1136),
u1136(1137), u1137(1138), u1138(1139), u1139(1140), u1140(1141), u1141(1142),
u1142(1143), u1143(1144), u1144(1145), u1145(1146), u1146(1147), u1147(1148),
u1148(1149), u1149(1150), u1150(1151), u1151(1152), u1152(1153), u1153(1154),
u1154(1155), u1155(1156), u1156(1157), u1157(1158), u1158(1159), u1159(1160),
u1160(1161), u1161(1162), u1162(1163), u1163(1164), u1164(1165), u1165(1166),
u1166(1167), u1167(1168), u1168(1169), u1169(1170), u1170(1171), u1171(1172),
u1172(1173), u1173(1174), u1174(1175), u1175(1176), u1176(1177), u1177(1178),

u1178(1179), u1179(1180), u1180(1181), u1181(1182), u1182(1183), u1183(1184),
u1184(1185), u1185(1186), u1186(1187), u1187(1188), u1188(1189), u1189(1190),
u1190(1191), u1191(1192), u1192(1193), u1193(1194), u1194(1195), u1195(1196),
u1196(1197), u1197(1198), u1198(1199), u1199(1200), u1200(1201), u1201(1202),
u1202(1203), u1203(1204), u1204(1205), u1205(1206), u1206(1207), u1207(1208),
u1208(1209), u1209(1210), u1210(1211), u1211(1212), u1212(1213), u1213(1214),
u1214(1215), u1215(1216), u1216(1217), u1217(1218), u1218(1219), u1219(1220),
u1220(1221), u1221(1222), u1222(1223), u1223(1224), u1224(1225), u1225(1226),
u1226(1227), u1227(1228), u1228(1229), u1229(1230), u1230(1231), u1231(1232),
u1232(1233), u1233(1234), u1234(1235), u1235(1236), u1236(1237), u1237(1238),
u1238(1239), u1239(1240), u1240(1241), u1241(1242), u1242(1243), u1243(1244),
u1244(1245), u1245(1246), u1246(1247), u1247(1248), u1248(1249), u1249(1250),
u1250(1251), u1251(1252), u1252(1253), u1253(1254), u1254(1255), u1255(1256),
u1256(1257), u1257(1258), u1258(1259), u1259(1260), u1260(1261), u1261(1262),
u1262(1263), u1263(1264), u1264(1265), u1265(1266), u1266(1267), u1267(1268),
u1268(1269), u1269(1270), u1270(1271), u1271(1272), u1272(1273), u1273(1274),
u1274(1275), u1275(1276), u1276(1277), u1277(1278), u1278(1279), u1279(1280),
u1280(1281), u1281(1282), u1282(1283), u1283(1284), u1284(1285), u1285(1286),
u1286(1287), u1287(1288), u1288(1289), u1289(1290), u1290(1291), u1291(1292),
u1292(1293), u1293(1294), u1294(1295), u1295(1296), u1296(1297), u1297(1298),
u1298(1299), u1299(1300), u1300(1301), u1301(1302), u1302(1303), u1303(1304),
u1304(1305), u1305(1306), u1306(1307), u1307(1308), u1308(1309), u1309(1310),
u1310(1311), u1311(1312), u1312(1313), u1313(1314), u1314(1315), u1315(1316),
u1316(1317), u1317(1318), u1318(1319), u1319(1320), u1320(1321), u1321(1322),
u1322(1323), u1323(1324), u1324(1325), u1325(1326), u1326(1327), u1327(1328),
u1328(1329), u1329(1330), u1330(1331), u1331(1332), u1332(1333), u1333(1334),
u1334(1335), u1335(1336), u1336(1337), u1337(1338), u1338(1339), u1339(1340),
u1340(1341), u1341(1342), u1342(1343), u1343(1344), u1344(1345), u1345(1346),
u1346(1347), u1347(1348), u1348(1349), u1349(1350), u1350(1351), u1351(1352),
u1352(1353), u1353(1354), u1354(1355), u1355(1356), u1356(1357), u1357(1358),
u1358(1359), u1359(1360), u1360(1361), u1361(1362), u1362(1363), u1363(1364),
u1364(1365), u1365(1366), u1366(1367), u1367(1368), u1368(1369), u1369(1370),
u1370(1371), u1371(1372), u1372(1373), u1373(1374), u1374(1375), u1375(1376),
u1376(1377), u1377(1378), u1378(1379), u1379(1380), u1380(1381), u1381(1382),
u1382(1383), u1383(1384), u1384(1385), u1385(1386), u1386(1387), u1387(1388),
u1388(1389), u1389(1390), u1390(1391), u1391(1392), u1392(1393), u1393(1394),
u1394(1395), u1395(1396), u1396(1397), u1397(1398), u1398(1399), u1399(1400),
u1400(1401), u1401(1402), u1402(1403), u1403(1404), u1404(1405), u1405(1406),
u1406(1407), u1407(1408), u1408(1409), u1409(1410), u1410(1411), u1411(1412),
u1412(1413), u1413(1414), u1414(1415), u1415(1416), u1416(1417), u1417(1418),
u1418(1419), u1419(1420), u1420(1421), u1421(1422), u1422(1423), u1423(1424),
u1424(1425), u1425(1426), u1426(1427), u1427(1428), u1428(1429), u1429(1430),
u1430(1431), u1431(1432), u1432(1433), u1433(1434), u1434(1435), u1435(1436),
u1436(1437), u1437(1438), u1438(1439), u1439(1440), u1440(1441), u1441(1442),
u1442(1443), u1443(1444), u1444(1445), u1445(1446), u1446(1447), u1447(1448),
u1448(1449), u1449(1450), u1450(1451), u1451(1452), u1452(1453), u1453(1454),
u1454(1455), u1455(1456), u1456(1457), u1457(1458), u1458(1459), u1459(1460),
u1460(1461), u1461(1462), u1462(1463), u1463(1464), u1464(1465), u1465(1466),
u1466(1467), u1467(1468), u1468(1469), u1469(1470), u1470(1471), u1471(1472),
u1472(1473), u1473(1474), u1474(1475), u1475(1476), u1476(1477), u1477(1478),
u1478(1479), u1479(1480), u1480(1481), u1481(1482), u1482(1483), u1483(1484),
u1484(1485), u1485(1486), u1486(1487), u1487(1488), u1488(1489), u1489(1490),
u1490(1491), u1491(1492), u1492(1493), u1493(1494), u1494(1495), u1495(1496),
u1496(1497), u1497(1498), u1498(1499), u1499(1500), u1500(1501), u1501(1502),
u1502(1503), u1503(1504), u1504(1505), u1505(1506), u1506(1507), u1507(1508),
u1508(1509), u1509(1510), u1510(1511), u1511(1512), u1512(1513), u1513(1514),
u1514(1515), u1515(1516), u1516(1517), u1517(1518), u1518(1519), u1519(1520),
u1520(1521), u1521(1522), u1522(1523), u1523(1524), u1524(1525), u1525(1526),
u1526(1527), u1527(1528), u1528(1529), u1529(1530), u1530(1531), u1531(1532),
u1532(1533), u1533(1534), u1534(1535), u1535(1536), u1536(1537), u1537(1538),
u1538(1539), u1539(1540), u1540(1541), u1541(1542), u1542(1543), u1543(1544),
u1544(1545), u1545(1546), u1546(1547), u1547(1548), u1548(1549), u1549(1550),
u1550(1551), u1551(1552), u1552(1553), u1553(1554), u1554(1555), u1555(1556),
u1556(1557), u1557(1558), u1558(1559), u1559(1560), u1560(1561), u1561(1562),

u1562(1563), u1563(1564), u1564(1565), u1565(1566), u1566(1567), u1567(1568),
u1568(1569), u1569(1570), u1570(1571), u1571(1572), u1572(1573), u1573(1574),
u1574(1575), u1575(1576), u1576(1577), u1577(1578), u1578(1579), u1579(1580),
u1580(1581), u1581(1582), u1582(1583), u1583(1584), u1584(1585), u1585(1586),
u1586(1587), u1587(1588), u1588(1589), u1589(1590), u1590(1591), u1591(1592),
u1592(1593), u1593(1594), u1594(1595), u1595(1596), u1596(1597), u1597(1598),
u1598(1599), u1599(1600), u1600(1601), u1601(1602), u1602(1603), u1603(1604),
u1604(1605), u1605(1606), u1606(1607), u1607(1608), u1608(1609), u1609(1610),
u1610(1611), u1611(1612), u1612(1613), u1613(1614), u1614(1615), u1615(1616),
u1616(1617), u1617(1618), u1618(1619), u1619(1620), u1620(1621), u1621(1622),
u1622(1623), u1623(1624), u1624(1625), u1625(1626), u1626(1627), u1627(1628),
u1628(1629), u1629(1630), u1630(1631), u1631(1632), u1632(1633), u1633(1634),
u1634(1635), u1635(1636), u1636(1637), u1637(1638), u1638(1639), u1639(1640),
u1640(1641), u1641(1642), u1642(1643), u1643(1644), u1644(1645), u1645(1646),
u1646(1647), u1647(1648), u1648(1649), u1649(1650), u1650(1651), u1651(1652),
u1652(1653), u1653(1654), u1654(1655), u1655(1656), u1656(1657), u1657(1658),
u1658(1659), u1659(1660), u1660(1661), u1661(1662), u1662(1663), u1663(1664),
u1664(1665), u1665(1666), u1666(1667), u1667(1668), u1668(1669), u1669(1670),
u1670(1671), u1671(1672), u1672(1673), u1673(1674), u1674(1675), u1675(1676),
u1676(1677), u1677(1678), u1678(1679), u1679(1680), u1680(1681), u1681(1682),
u1682(1683), u1683(1684), u1684(1685), u1685(1686), u1686(1687), u1687(1688),
u1688(1689), u1689(1690), u1690(1691), u1691(1692), u1692(1693), u1693(1694),
u1694(1695), u1695(1696), u1696(1697), u1697(1698), u1698(1699), u1699(1700),
u1700(1701), u1701(1702), u1702(1703), u1703(1704), u1704(1705), u1705(1706),
u1706(1707), u1707(1708), u1708(1709), u1709(1710), u1710(1711), u1711(1712),
u1712(1713), u1713(1714), u1714(1715), u1715(1716), u1716(1717), u1717(1718),
u1718(1719), u1719(1720), u1720(1721), u1721(1722), u1722(1723), u1723(1724),
u1724(1725), u1725(1726), u1726(1727), u1727(1728), u1728(1729), u1729(1730),
u1730(1731), u1731(1732), u1732(1733), u1733(1734), u1734(1735), u1735(1736),
u1736(1737), u1737(1738), u1738(1739), u1739(1740), u1740(1741), u1741(1742),
u1742(1743), u1743(1744), u1744(1745), u1745(1746), u1746(1747), u1747(1748),
u1748(1749), u1749(1750), u1750(1751), u1751(1752), u1752(1753), u1753(1754),
u1754(1755), u1755(1756), u1756(1757), u1757(1758), u1758(1759), u1759(1760),
u1760(1761), u1761(1762), u1762(1763), u1763(1764), u1764(1765), u1765(1766),
u1766(1767), u1767(1768), u1768(1769), u1769(1770), u1770(1771), u1771(1772),
u1772(1773), u1773(1774), u1774(1775), u1775(1776), u1776(1777), u1777(1778),
u1778(1779), u1779(1780), u1780(1781), u1781(1782), u1782(1783), u1783(1784),
u1784(1785), u1785(1786), u1786(1787), u1787(1788), u1788(1789), u1789(1790),
u1790(1791), u1791(1792), u1792(1793), u1793(1794), u1794(1795), u1795(1796),
u1796(1797), u1797(1798), u1798(1799), u1799(1800), u1800(1801), u1801(1802),
u1802(1803), u1803(1804), u1804(1805), u1805(1806), u1806(1807), u1807(1808),
u1808(1809), u1809(1810), u1810(1811), u1811(1812), u1812(1813), u1813(1814),
u1814(1815), u1815(1816), u1816(1817), u1817(1818), u1818(1819), u1819(1820),
u1820(1821), u1821(1822), u1822(1823), u1823(1824), u1824(1825), u1825(1826),
u1826(1827), u1827(1828), u1828(1829), u1829(1830), u1830(1831), u1831(1832),
u1832(1833), u1833(1834), u1834(1835), u1835(1836), u1836(1837), u1837(1838),
u1838(1839), u1839(1840), u1840(1841), u1841(1842), u1842(1843), u1843(1844),
u1844(1845), u1845(1846), u1846(1847), u1847(1848), u1848(1849), u1849(1850),
u1850(1851), u1851(1852), u1852(1853), u1853(1854), u1854(1855), u1855(1856),
u1856(1857), u1857(1858), u1858(1859), u1859(1860), u1860(1861), u1861(1862),
u1862(1863), u1863(1864), u1864(1865), u1865(1866), u1866(1867), u1867(1868),
u1868(1869), u1869(1870), u1870(1871), u1871(1872), u1872(1873), u1873(1874),
u1874(1875), u1875(1876), u1876(1877), u1877(1878), u1878(1879), u1879(1880),
u1880(1881), u1881(1882), u1882(1883), u1883(1884), u1884(1885), u1885(1886),
u1886(1887), u1887(1888), u1888(1889), u1889(1890), u1890(1891), u1891(1892),
u1892(1893), u1893(1894), u1894(1895), u1895(1896), u1896(1897), u1897(1898),
u1898(1899), u1899(1900), u1900(1901), u1901(1902), u1902(1903), u1903(1904),
u1904(1905), u1905(1906), u1906(1907), u1907(1908), u1908(1909), u1909(1910),
u1910(1911), u1911(1912), u1912(1913), u1913(1914), u1914(1915), u1915(1916),
u1916(1917), u1917(1918), u1918(1919), u1919(1920), u1920(1921), u1921(1922),
u1922(1923), u1923(1924), u1924(1925), u1925(1926), u1926(1927), u1927(1928),
u1928(1929), u1929(1930), u1930(1931), u1931(1932), u1932(1933), u1933(1934),
u1934(1935), u1935(1936), u1936(1937), u1937(1938), u1938(1939), u1939(1940),
u1940(1941), u1941(1942), u1942(1943), u1943(1944), u1944(1945), u1945(1946),

```

| | | u1946(1947), u1947(1948), u1948(1949), u1949(1950), u1950(1951), u1951(1952),
| | | u1952(1953), u1953(1954), u1954(1955), u1955(1956), u1956(1957), u1957(1958),
| | | u1958(1959), u1959(1960), u1960(1961), u1961(1962), u1962(1963), u1963(1964),
| | | u1964(1965), u1965(1966), u1966(1967), u1967(1968), u1968(1969), u1969(1970),
| | | u1970(1971), u1971(1972), u1972(1973), u1973(1974), u1974(1975), u1975(1976),
| | | u1976(1977), u1977(1978), u1978(1979), u1979(1980), u1980(1981), u1981(1982),
| | | u1982(1983), u1983(1984), u1984(1985), u1985(1986), u1986(1987), u1987(1988),
| | | u1988(1989), u1989(1990), u1990(1991), u1991(1992), u1992(1993), u1993(1994),
| | | u1994(1995), u1995(1996), u1996(1997), u1997(1998), u1998(1999), u1999(2000)
| | | +--- -R-- String outputName(2)
| | | | Textual Convention: DisplayString
| | | | Size: 1..4
| | | +--- -RW- Integer32 outputGroup(3)
| | | | Range: 1..63
| | | +--- -R-- BitString outputStatus(4)
| | | | Values: outputOn(0), outputInhibit(1), outputFailureMinSenseVoltage(2),
| | | | outputFailureMaxSenseVoltage(3), outputFailureMaxTerminalVoltage(4),
| | | | outputFailureMaxCurrent(5), outputFailureMaxTemperature(6), outputFailureMaxPower(7),
| | | | outputFailureTimeout(9), outputCurrentLimited(10), outputRampUp(11), outputRampDown(12),
| | | | outputEnableKill(13), outputEmergencyOff(14)
| | | +--- -R-- Opaque outputMeasurementSenseVoltage(5)
| | | | Textual Convention: Float
| | | | Size: 7
| | | +--- -R-- Opaque outputMeasurementTerminalVoltage(6)
| | | | Textual Convention: Float
| | | | Size: 7
| | | +--- -R-- Opaque outputMeasurementCurrent(7)
| | | | Textual Convention: Float
| | | | Size: 7
| | | +--- -R-- EnumVal outputMeasurementTemperature(8)
| | | | Values: ok(-128), failure(127)
| | | +--- -RW- EnumVal outputSwitch(9)
| | | | Values: off(0), on(1), resetEmergencyOff(2), setEmergencyOff(3), clearEvents(10)
| | | +--- -RW- Opaque outputVoltage(10)
| | | | Textual Convention: Float
| | | | Size: 7
| | | +--- -RW- Integer32 outputAdjustVoltage(11)
| | | | Range: -128..127
| | | +--- -RW- Opaque outputCurrent(12)
| | | | Textual Convention: Float
| | | | Size: 7
| | | +--- -RW- Opaque outputVoltageRiseRate(13)
| | | | Textual Convention: Float
| | | | Size: 7
| | | +--- -RW- Opaque outputVoltageFallRate(14)
| | | | Textual Convention: Float
| | | | Size: 7
| | | +--- -RW- Integer32 outputSupervisionBehavior(15)
| | | | Range: 0..65535
| | | +--- -RW- Opaque outputSupervisionMinSenseVoltage(16)
| | | | Textual Convention: Float
| | | | Size: 7
| | | +--- -RW- Opaque outputSupervisionMaxSenseVoltage(17)
| | | | Textual Convention: Float
| | | | Size: 7
| | | +--- -RW- Opaque outputSupervisionMaxTerminalVoltage(18)
| | | | Textual Convention: Float
| | | | Size: 7
| | | +--- -RW- Opaque outputSupervisionMaxCurrent(19)
| | | | Textual Convention: Float
| | | | Size: 7
| | | +--- -RW- Opaque outputConfigMaxSenseVoltage(21)
| | | | Textual Convention: Float
| | | | Size: 7

```

```

| | +-- -RW- Opaque outputConfigMaxTerminalVoltage(22)
| | | Textual Convention: Float
| | | Size: 7
| | +-- -RW- Opaque outputConfigMaxCurrent(23)
| | | Textual Convention: Float
| | | Size: 7
| | +-- -RW- Opaque outputSupervisionMaxPower(24)
| | | Textual Convention: Float
| | | Size: 7
| | +-- -RW- Opaque outputCurrentRiseRate(25)
| | | Textual Convention: Float
| | | Size: 7
| | +-- -RW- Opaque outputCurrentFallRate(26)
| | | Textual Convention: Float
| | | Size: 7
| | +-- -RW- INTEGER outputTripTimeMaxCurrent(27)
| | | Range: 0..4000
| | +-- -R-- Opaque outputHardwareLimitVoltage(28)
| | | Textual Convention: Float
| | | Size: 7
| | +-- -R-- Opaque outputHardwareLimitCurrent(29)
| | | Textual Convention: Float
| | | Size: 7
| | +-- -RW- Opaque outputConfigGainSenseVoltage(30)
| | | Textual Convention: Float
| | | Size: 7
| | +-- -RW- Opaque outputConfigOffsetSenseVoltage(31)
| | | Textual Convention: Float
| | | Size: 7
| | +-- -RW- Opaque outputConfigGainTerminalVoltage(32)
| | | Textual Convention: Float
| | | Size: 7
| | +-- -RW- Opaque outputConfigOffsetTerminalVoltage(33)
| | | Textual Convention: Float
| | | Size: 7
| | +-- -RW- Opaque outputConfigGainCurrent(34)
| | | Textual Convention: Float
| | | Size: 7
| | +-- -RW- Opaque outputConfigOffsetCurrent(35)
| | | Textual Convention: Float
| | | Size: 7
| | +-- -RW- EnumVal outputRegulationMode(38)
| | | Values: fast(0), moderate(1), slow(2)
| | +-- -RW- Integer32 outputConfigMaxTemperature(39)
| |
| | +-- -R-- Integer32 groupsNumber(3)
| | | Range: 1..1999
| |
| | +--groupsTable(4)
| | |
| | | +--groupsEntry(1)
| | | | Index: groupsIndex
| | | |
| | | | +-- ---- Integer32 groupsIndex(1)
| | | | | Range: 0..1999
| | | | +-- -RW- EnumVal groupsSwitch(9)
| | | | | Values: undefined(-1), off(0), on(1), resetEmergencyOff(2), setEmergencyOff(3), disableKill(4),
| | | | | enableKill(5), clearEvents(10)
| |
| | +--sensor(4)
| | | +-- -R-- Integer32 sensorNumber(1)
| | | | Range: 0..8
| | |
| | | +--sensorTable(2)

```

```

|
| +--sensorEntry(1)
| | Index: sensorIndex
| |
| | +-- ---- EnumVal sensorIndex(1)
| | | Values: temp1(1), temp2(2), temp3(3), temp4(4), temp5(5), temp6(6), temp7(7), temp8(8)
| | +-- -R-- Integer32 sensorTemperature(2)
| | | Range: -128..127
| | +-- -RW- Integer32 sensorWarningThreshold(3)
| | | Range: 0..127
| | +-- -RW- Integer32 sensorFailureThreshold(4)
| | | Range: 0..127
| | +-- -RW- Integer32 sensorAlarmThreshold(6)
| | | Range: 0..127
|
+--communication(5)
| +--snmp(1)
| |
| | +--snmpCommunityTable(1)
| | |
| | | +--snmpCommunityEntry(1)
| | | | Index: snmpAccessRight
| | | |
| | | | +-- ---- EnumVal snmpAccessRight(1)
| | | | | Values: public(1), private(2), admin(3), guru(4)
| | | | +-- -RW- String snmpCommunityName(2)
| | | | | Size: 0..14
| | |
| | | +-- -RW- Integer32 snmpPort(2)
| | | +-- -RW- String firmwareUpdate(10)
| | | | Size: 0..30
| | | +-- -R-- IpAddr ipDynamicAddress(11)
| | | +-- -RW- IpAddr ipStaticAddress(12)
| | | +-- -RW- String macAddress(13)
| | | | Size: 6
| |
| +--can(2)
| | +-- -RW- Integer32 canBitRate(1)
| | +-- -R-- String canReceive(2)
| | | Size: 14
| | +-- -RW- String canTransmit(3)
| | | Size: 14
|
+--powersupply(6)
| +-- -R-- String psSerialNumber(2)
| | Textual Convention: DisplayString
| | | Size: 0..255
| +-- -RW- Integer32 psOperatingTime(3)
| +-- -R-- Integer32 psAuxiliaryNumber(4)
| | Range: 0..8
|
+--psAuxiliaryTable(5)
| |
| | +--psAuxiliaryEntry(1)
| | | Index: psAuxiliaryIndex
| | |
| | | +-- ---- EnumVal psAuxiliaryIndex(1)
| | | | Values: u0(1), u1(2), u2(3), u3(4), u4(5), u5(6), u6(7), u7(8)
| | | +-- -R-- Opaque psAuxiliaryMeasurementVoltage(3)
| | | | Textual Convention: Float
| | | | Size: 7
| | | +-- -R-- Opaque psAuxiliaryMeasurementCurrent(4)
| | | | Textual Convention: Float
| | | | Size: 7

```

```

| |
| +-- -RW- String  psDirectAccess(1024)
|     Size: 1..14
|
+--fantray(7)
| +-- -RW- String  fanSerialNumber(2)
|     Textual Convention: DisplayString
|     Size: 0..14
| +-- -RW- Integer32 fanOperatingTime(3)
| +-- -R-- Integer32 fanAirTemperature(4)
| +-- -RW- Integer32 fanSwitchOffDelay(5)
|     Range: 0..900
| +-- -RW- Integer32 fanNominalSpeed(6)
| +-- -RW- Integer32 fanNumberOfFans(7)
|     Range: 0..12
|
+--fanSpeedTable(8)
| |
| | +--fanSpeedEntry(1)
| | | Index: fanNumber
| | |
| | | +-- ---- Integer32 fanNumber(1)
| | | | Range: 1..12
| | | +-- -R-- Integer32 fanSpeed(2)
| | |
| | +-- -RW- INTEGER  fanMaxSpeed(9)
| | +-- -RW- INTEGER  fanMinSpeed(10)
| | +-- -RW- Integer32 outputConfigFanMaxSpeed(11)
| | +-- -RW- Integer32 outputConfigFanMinSpeed(12)
| |
+--rack(8)
+--signal(9)
+-- -R-- Integer32 numberOfAnalogInputs(1)
|     Range: 0..8
|
+--analogInputTable(2)
| |
| | +--analogInputEntry(1)
| | | Index: analogInputIndex
| | |
| | | +-- ---- Integer32 analogInputIndex(1)
| | | | Range: 1..8
| | | +-- -R-- Opaque  analogMeasurementVoltage(2)
| | | | Textual Convention: Float
| | | | Size: 7
| | | +-- -R-- Opaque  analogMeasurementCurrent(3)
| | | | Textual Convention: Float
| | | | Size: 7
| | |
| | +-- -R-- BitString digitalInput(5)
| | | Values: d0(0), d1(1), d2(2), d3(3), d4(4), d5(5), d6(6), d7(7)
| | +-- -R-- BitString digitalOutput(6)
| | | Values: d0(0), d1(1), d2(2), d3(3), d4(4), d5(5), d6(6), d7(7)

```

12 MPOD Firmware Update

For Bootloader from revision 1.5 and Firmware revision 2.*.0.15 and higher

- 1) In addition to the latest firmware files you need the **MUSEcontrol** program version 2.0.910.0 or higher. All files can be download from the WIENER file server <http://file.wiener-d.com/software/MUSEcontrol/> and <http://file.wiener-d.com/firmware/MPOD/>.
- 2) Connect the MPOD to the Computer via USB
- 3) Start the MUSEcontrol program and select the tab “system”. In the opened pull down menu select the item “Firmware Update” to update the device via USB.

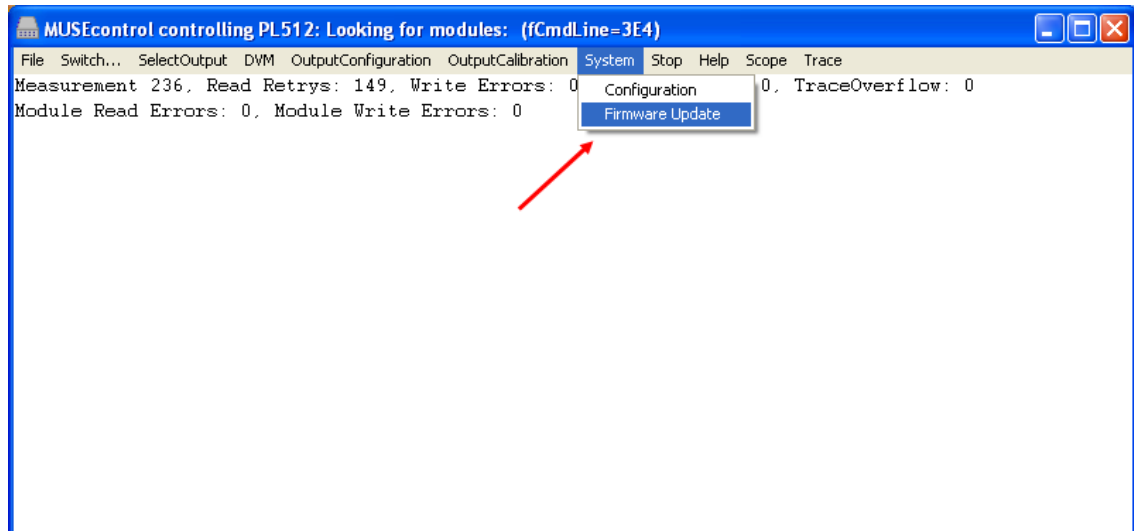

- 4) Hit the button “browse” to scan the device for current version of boot loader and firmware.

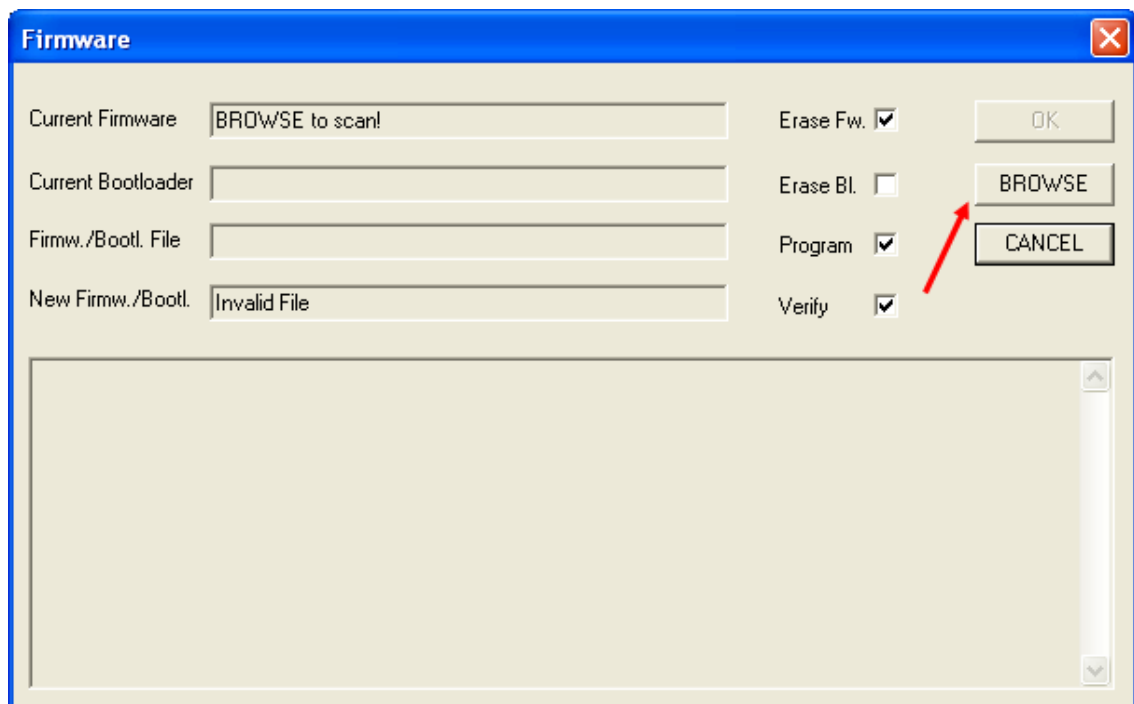

- 5) Check the version of the current firmware or boot loader. There are three options:

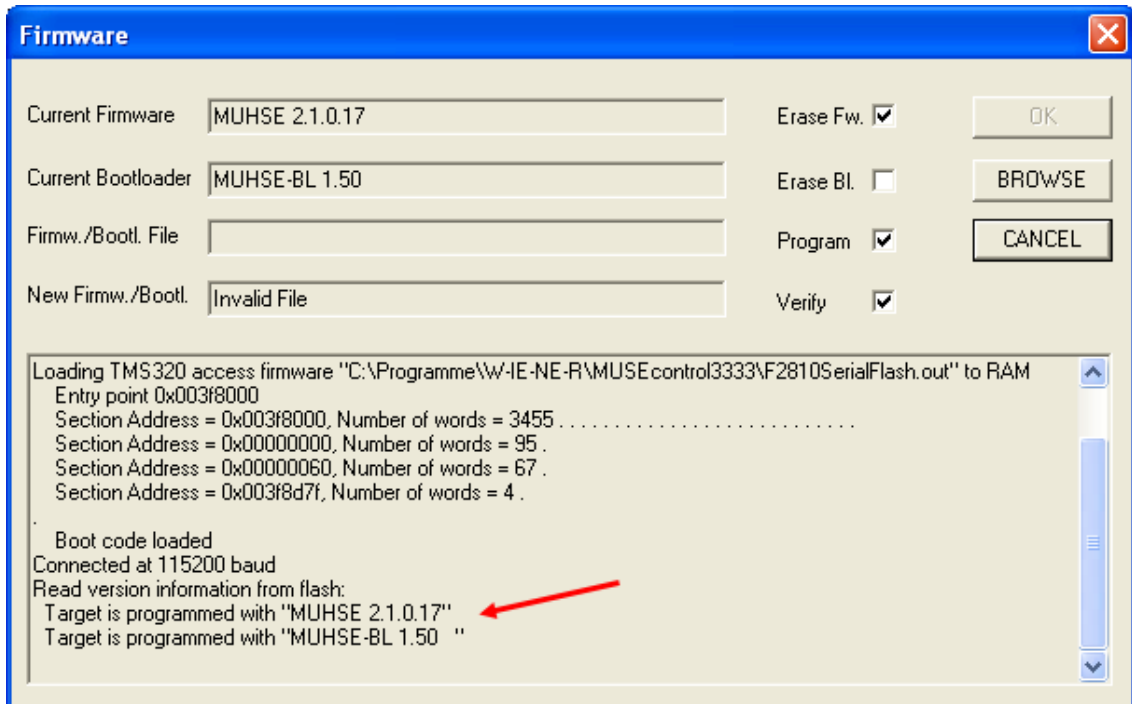

Option 1) Check “Erase Fw.” (erase firmware) and “Erase BL.” (erase boot loader) if the current firmware is older than 2.*.0.15 or it is a firmware without boot loader. After that push the button “browse” to scan the flash. In some minutes select the new boot loader file in the automatically opened file menu. Press the button “Ok”. Now the whole flash will be erased and the new boot loader will be installed.

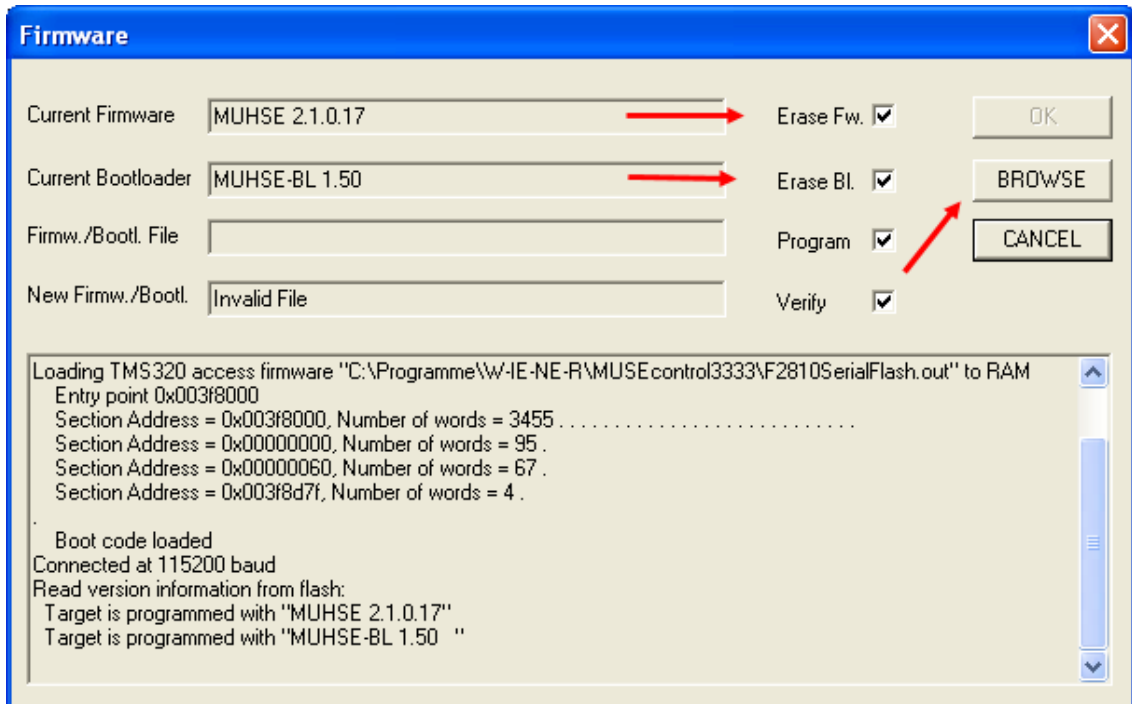

When the install process is done hit the button “cancel” to restart the system. It is recommended to close the MUSEcontrol program before restarting.

A window which indicates a communication problem appears. The reason for this is that only the bootloader without firmware is installed. Ignore this message by pushing the button “cancel”.

Also ignore the no modu

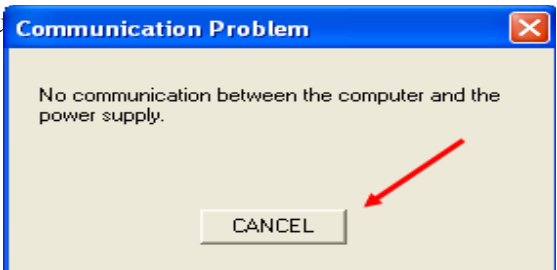

Follow the step 1 and 2. Execute the instructions of option 2.

Option 2) Check “Erase Fw.” (erase firmware) if there no current, legal firmware is available or a newer one should be installed. After that push the button “browse” to scan the flash. In some minutes select the new firmware file in the automatically opened file menu. Press the button “Ok”. Now the firmware partition in the flash will be formatted and the new firmware will be installed.

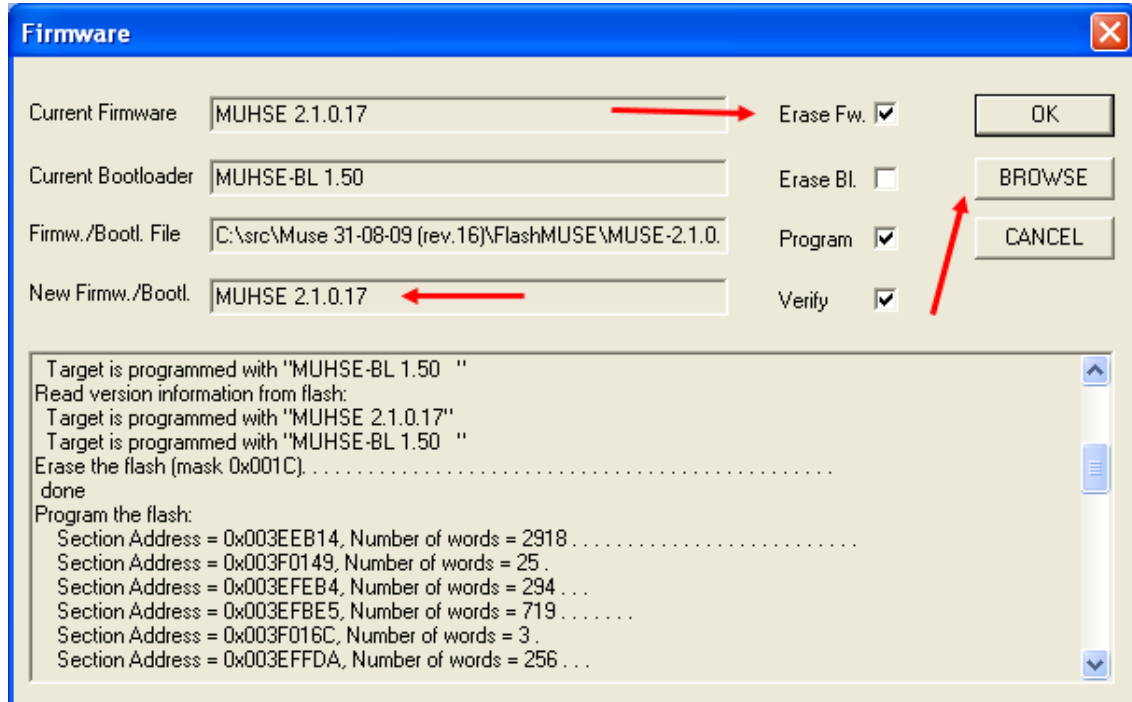

When the install process is done hit the button “cancel” to restart the system. It is recommended to close the MUSEcontrol program before restarting.

Option 3) Check “Erase Bl.” (erase boot loader) if there an older boot loader (from version 1.5) and a newer one should be installed. If no boot loader is available chose option 1. After that push the button “browse” to scan the flash. In some minutes select the new boot loader file in the automatically opened file menu. Press the button “Ok”. Now the boot loader partition in the flash will be formatted and the new boot loader will be installed.

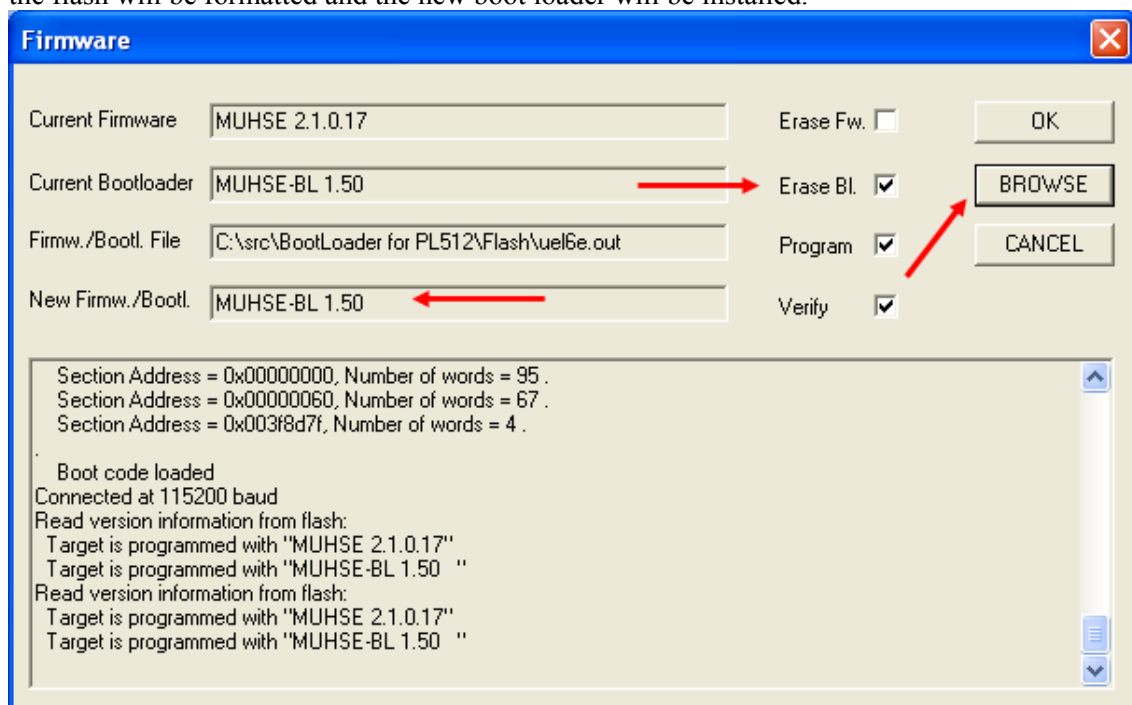

When the install process is done hit the button “cancel” to restart the system. It is recommended to close the MUSEcontrol program before restarting.

13 MPOD Display Firmware Update

MPOD display firmware update is possible with all displays using firmware Doom 1.0.1344.0 or above (see <http://file.wiener-d.com/firmware/MPOD-Display>)

The update is done via Ethernet connected to the MPOD controller with the special utility **PIC32PL.exe** (<http://file.wiener-d.com/software/PIC32BL>)

Please install this software on your Windows PC start the program and perform the following procedure:

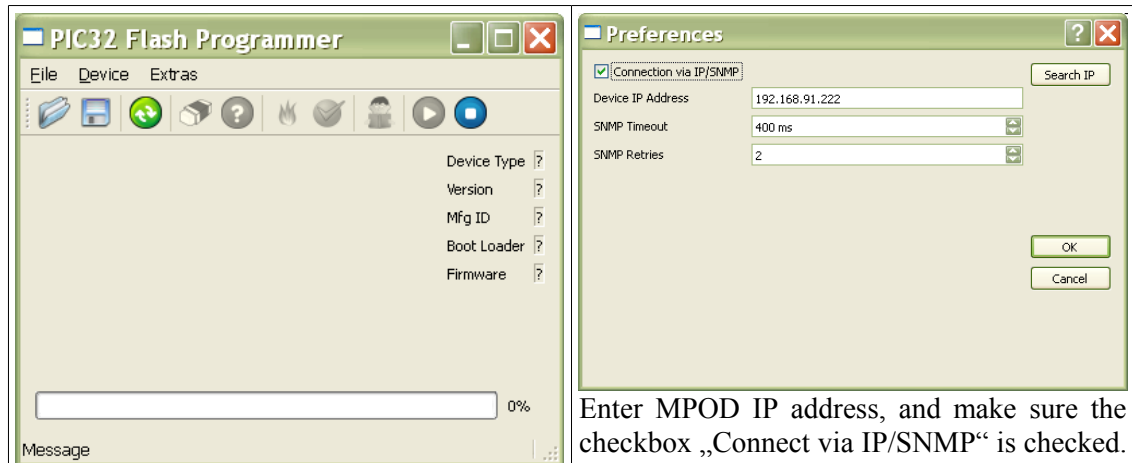

Enter MPOD IP address, and make sure the checkbox „Connect via IP/SNMP“ is checked. Then click „OK“.

Select „Extras → Preferences“

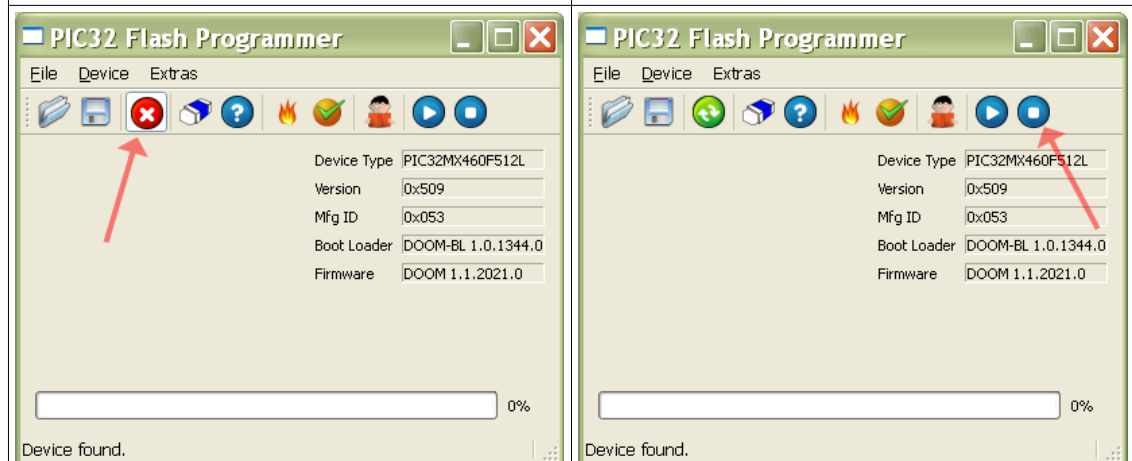

Click „Device → Connect“ (green circle). The connection to the display firmware is established, and the icon changed to „Disconnect“ (red circle with x)

Click the „Execute Boot Loader“ icon at the right (blue circle with square). Normal operation of the display is stopped and boot loader operation is started.

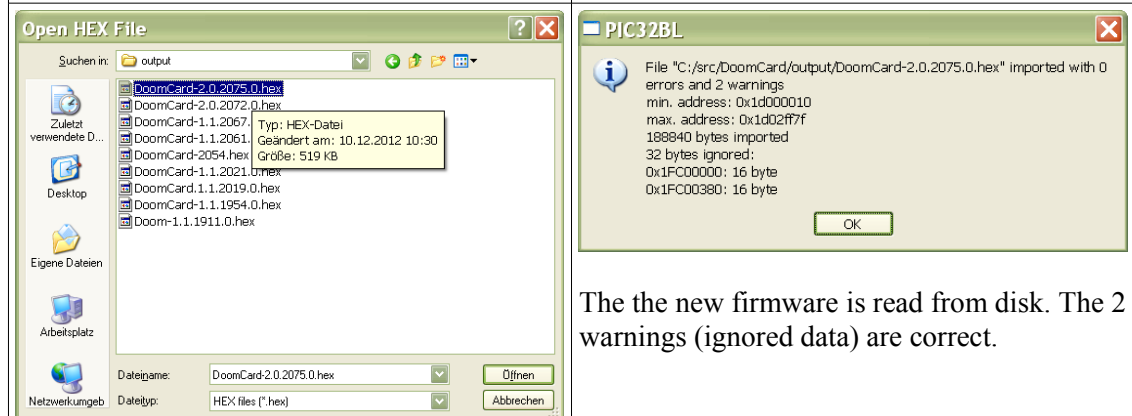

The the new firmware is read from disk. The 2 warnings (ignored data) are correct.

Now use „File → Open“ select firmware file



Click the „Erase“ icon to erase the previous firmware.

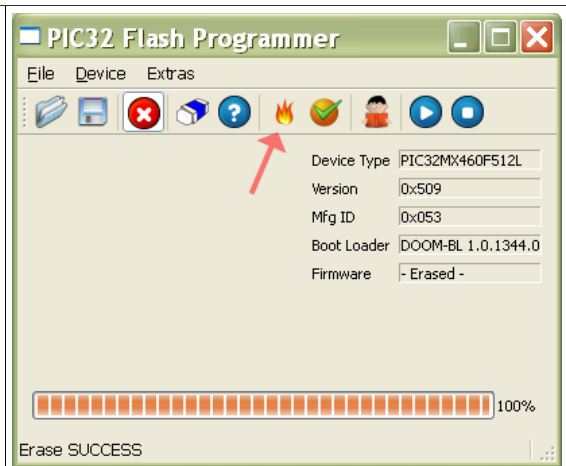

Click „Program“ to program the new firmware.

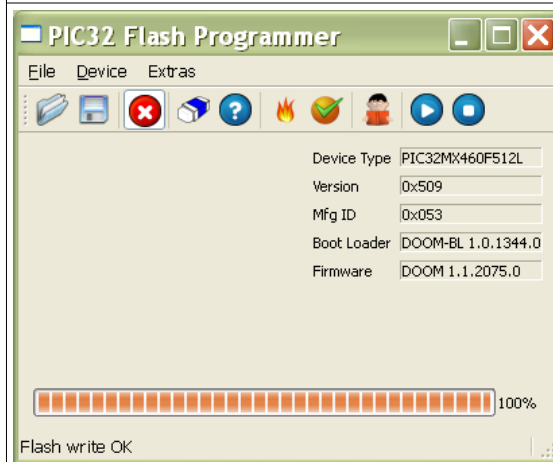

A verify is done automatically.

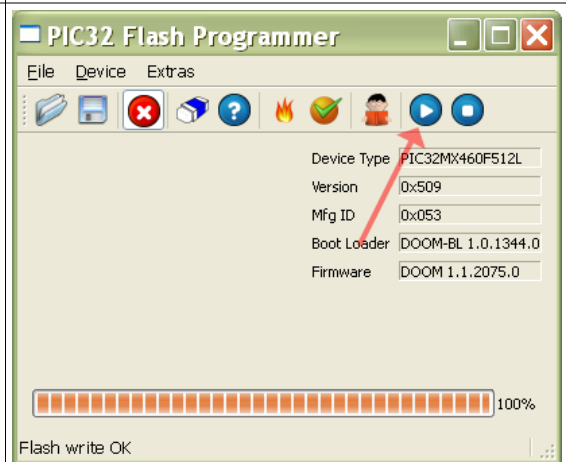

Now click the „Run new firmware“ icon (blue circle with triangle) to leave the boot loader and execute the new firmware.

14 ISEG HV Module Firmware Update via Ethernet / SNMP

Download ISEG SNMP tools and latest firmware from ISEG WEB-Site:

<http://www.iseg-hv.com/support/>

The firmware may have to be requested by providing HV module name / part number and serial number

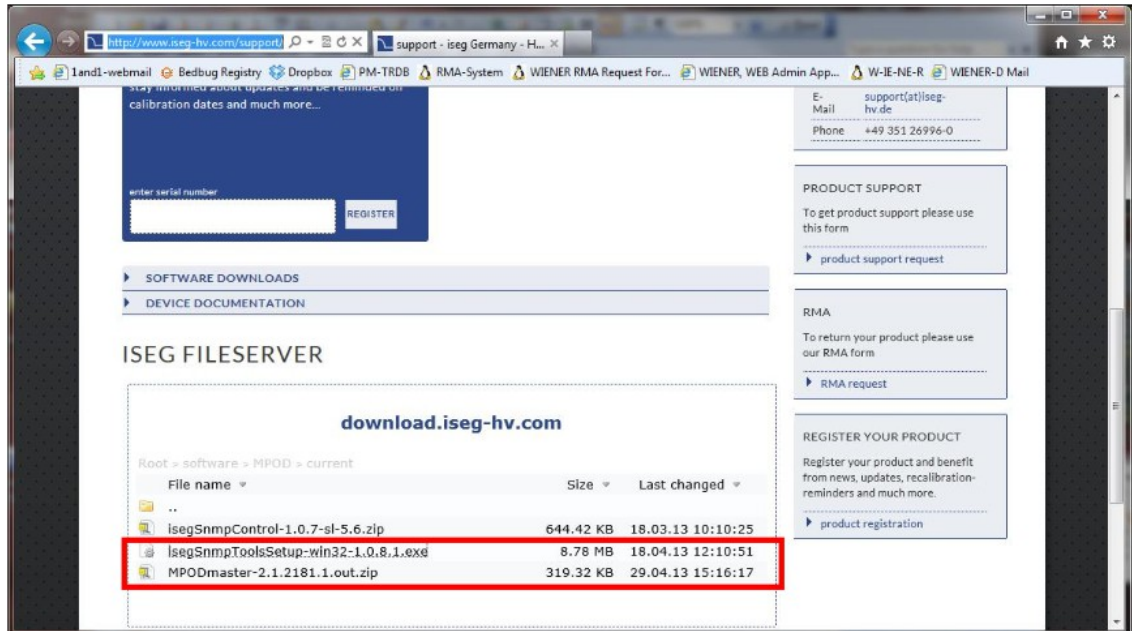

2. Perform MPOD firmware upgrade to MPODMaster 2.1.2181.1 or higher using MUSEcontrol and the USB connection (see instructions in MPOD manual)

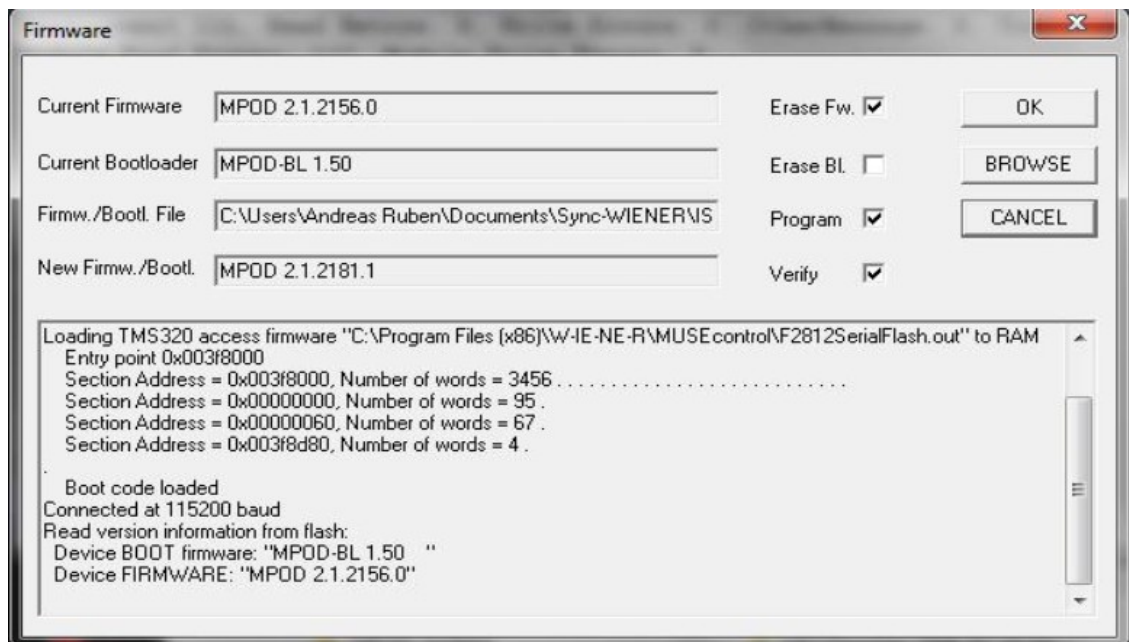

3. Run isegSnmpToolsSetup-win32-1.0.8.1.exe to install the ISEG software.
Remove all modules from the MPOD except the one you want to update (it's possible to update multiple modules sequentially, but it is safer to start with only one first)
4. Close all programs that connect to the MPOD
5. Start **isegSnmpFlash.exe**
6. Please insert the correct MPOD IP address and click connect
7. A list of modules in this MPOD appears (in this case, only one)

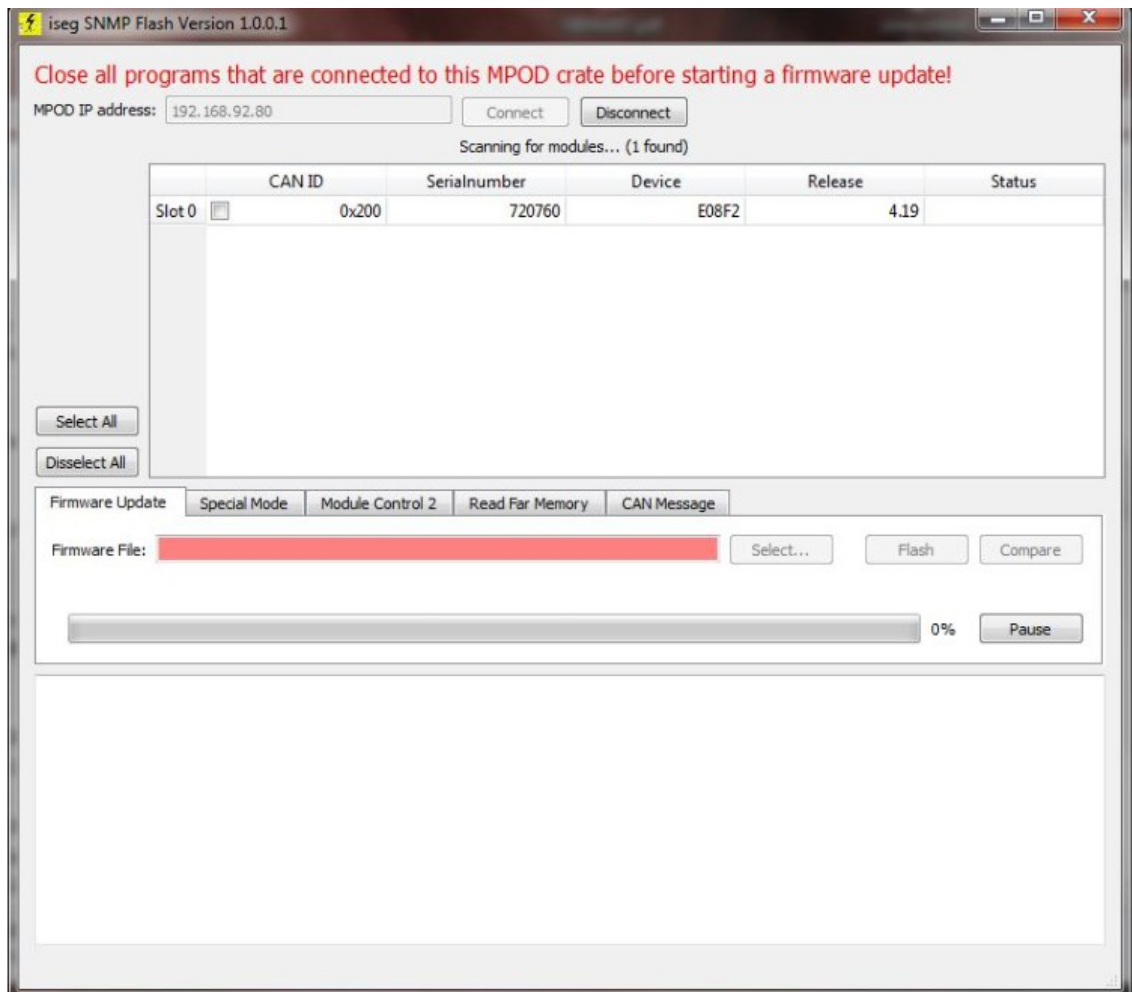

8. Check the box in the column CAN ID to flash/firmware upgrade this module

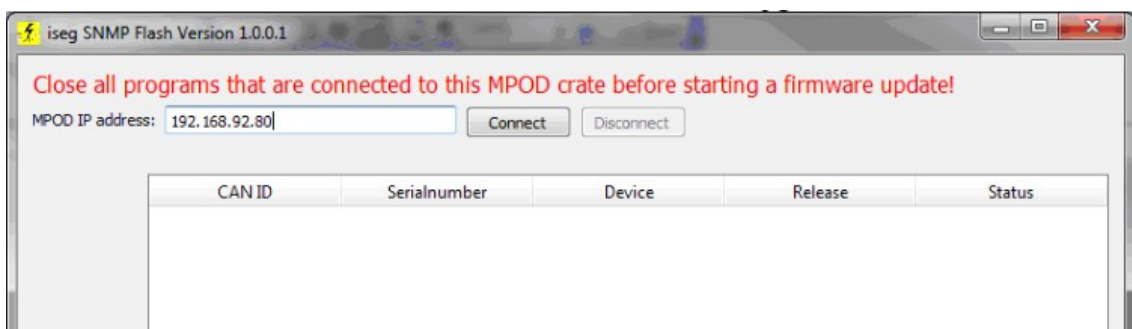

9. If the text field with the firmware name appears red, select the

HEX file with "Select..." either E08F2_421.hex (or other recommended firmware file)

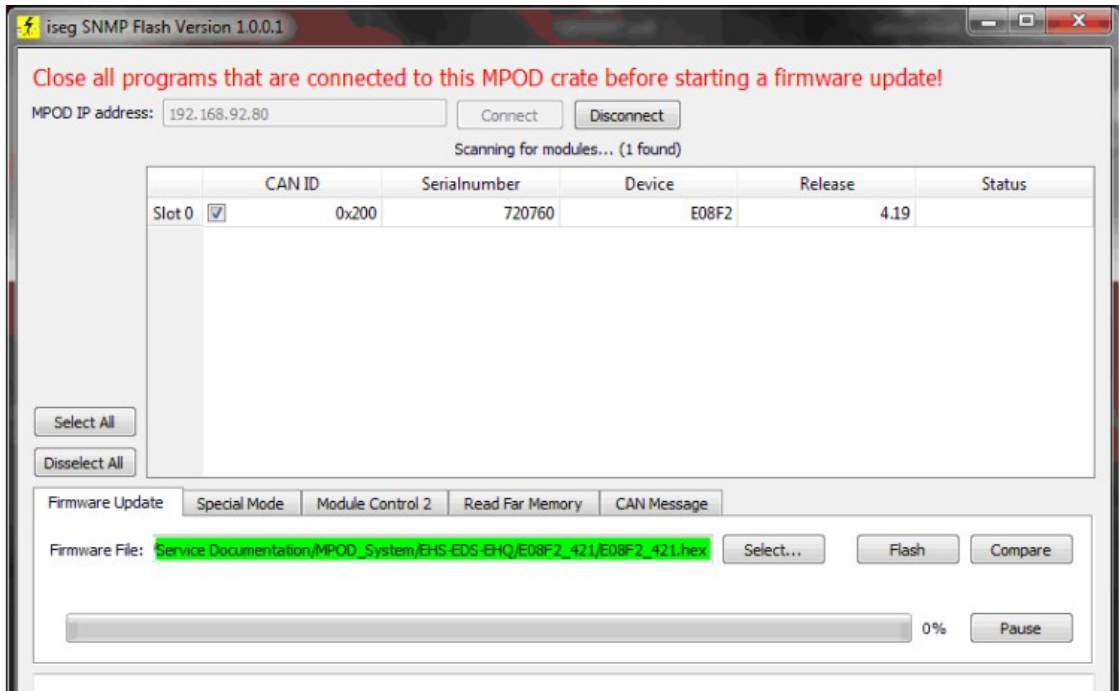

10. Click Flash. The update consists of three steps: Flash, Compare and Postflash. After Postflash, the Table shows "Done" in the status column.

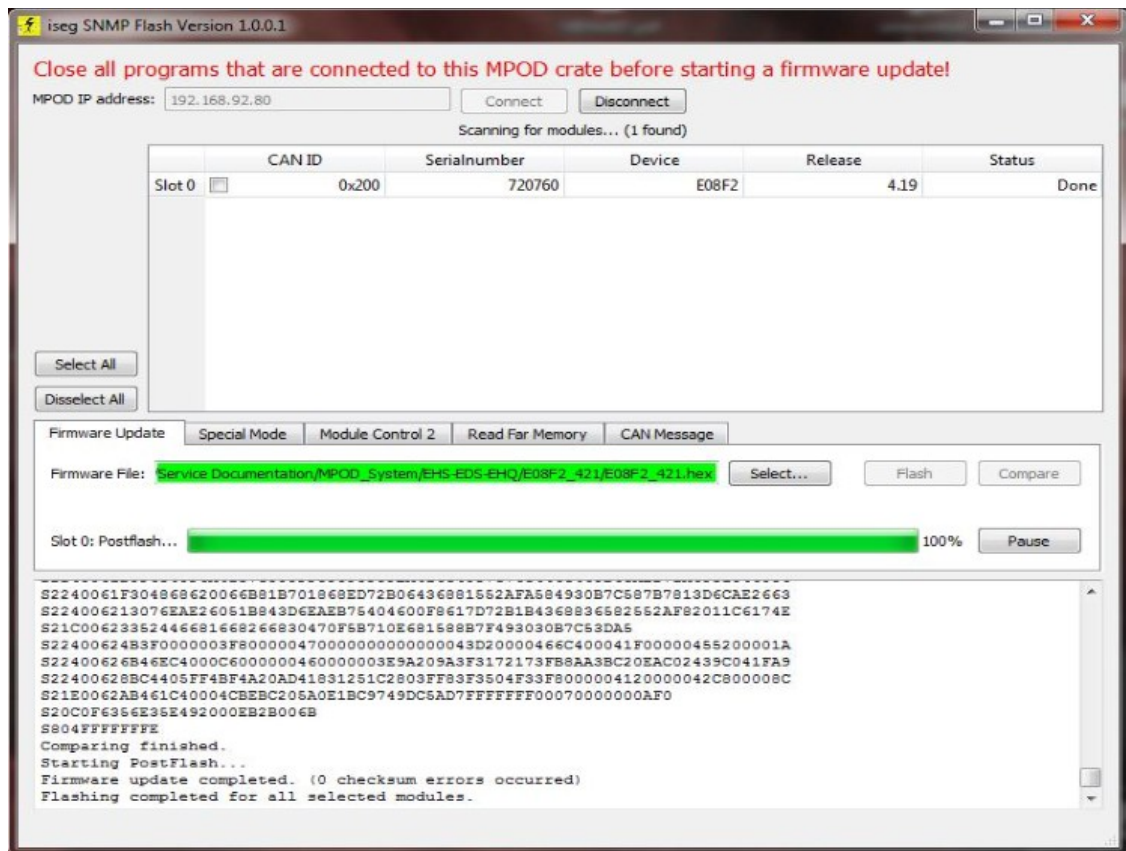

11. You can now close the program, re-power the MPOD and control it again with iseg SNMP Control.

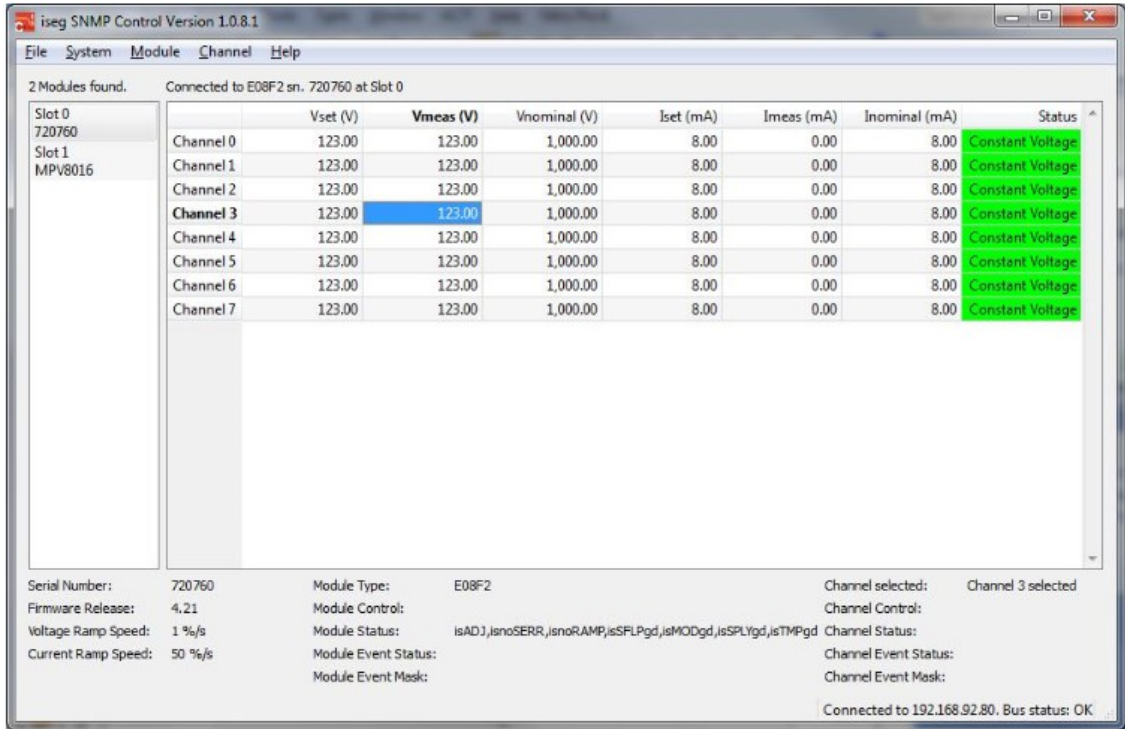
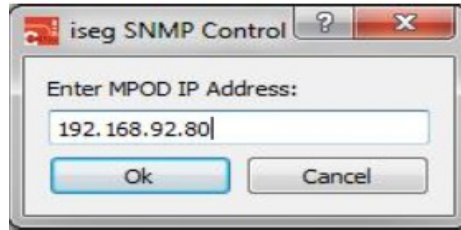

If anything goes wrong, e.g. the update stops and the progress bar is not moving for 2 minutes or more, you can close the program, re-power the MPOD and try again.